



IRIG STANDARD 106-01, Part 1

TELEMETRY GROUP

TELEMETRY STANDARDS

**WHITE SANDS MISSILE RANGE
KWAJALEIN MISSILE RANGE
YUMA PROVING GROUND
DUGWAY PROVING GROUND
ABERDEEN TEST CENTER
NATIONAL TRAINING CENTER**

**ATLANTIC FLEET WEAPONS TRAINING FACILITY
NAVAL AIR WARFARE CENTER WEAPONS DIVISION
NAVAL AIR WARFARE CENTER AIRCRAFT DIVISION
NAVAL UNDERSEA WARFARE CENTER DIVISION, NEWPORT
PACIFIC MISSILE RANGE FACILITY
NAVAL UNDERSEA WARFARE CENTER DIVISION, KEYPORT**

**30TH SPACE WING
45TH SPACE WING
AIR FORCE FLIGHT TEST CENTER
AIR ARMAMENT CENTER
AIR WARFARE CENTER
ARNOLD ENGINEERING DEVELOPMENT CENTER
BARRY M. GOLDWATER RANGE
UTAH TEST AND TRAINING RANGE**

NEVADA TEST SITE

**DISTRIBUTION A: APPROVED FOR PUBLIC RELEASE;
DISTRIBUTION IS UNLIMITED**

IRIG STANDARD 106-01, Part 1

TELEMETRY STANDARDS

FEBRUARY 2001

Prepared by

**TELEMETRY GROUP
RANGE COMMANDERS COUNCIL**

Published by

**Secretariat
Range Commanders Council
U.S. Army White Sands Missile Range,
New Mexico 88002-5110**

**THIS DOCUMENT IS AVAILABLE ON THE
RANGE COMMANDERS COUNCIL WEBSITE AT
<http://jcs.mil/RCC>**

TABLE OF CONTENTS

	<u>Page</u>
CHANGES TO THIS EDITION	iii
ACRONYMS	xxv
FORWARD	xxix
CHAPTER 1 - INTRODUCTION, PART 1	1-1
CHAPTER 2 - TRANSMITTER AND RECEIVER SYSTEMS	2-1
2.1 Radio Frequency Standards for Telemetry.....	2-1
2.2 Definitions.....	2-1
2.3 UHF Bands.....	2-2
2.3.1 Allocation of the L Band (1435 to 1535 MHz).....	2-2
2.3.1.1 1435 to 1525 MHz	2-2
2.3.1.2 1525 to 1530 MHz	2-2
2.3.1.3 1530 to 1535 MHz	2-3
2.3.2 Allocation of the S Band (2200 to 2300 MHz).....	2-3
2.3.2.1 2200 to 2290 MHz	2-3
2.3.2.2 2290 to 2300 MHz	2-3
2.3.3 Allocation of the Upper S Band (2310 to 2390 MHz).....	2-3
2.3.3.1 2310 to 2360 MHz	2-3
2.3.3.2 2360 to 2390 MHz	2-3
2.4 UHF Telemetry Transmitter Systems	2-4
2.4.1 Center Frequency Tolerance.....	2-4
2.4.2 Channel Bandwidth Definitions.....	2-4
2.4.2.1 Standard Bandwidth Signal.....	2-4
2.4.2.2 Wide Bandwidth Signal	2-4
2.4.3 Channelization	2-4
2.4.3.1 Standard Bandwidth Channels.....	2-4
2.4.3.2 Wide Bandwidth Channels	2-4
2.4.4 Output Power	2-5
2.4.5 Modulation	2-5
2.4.5.1 Characteristics of FQPSK-B	2-5
2.4.5.1.1 Differential Encoding.....	2-5
2.4.5.1.2 Data Randomization.....	2-6
2.4.5.1.3 Quadrature Modulator Phase Map	2-6

	<u>Page</u>
2.4.5.1.4	Bit Rate 2-6
2.4.5.1.5	Transmitter Phase Noise 2-7
2.4.5.1.6	Carrier Suppression..... 2-7
2.4.5.2	Modulation Polarity 2-7
2.4.6	Spurious Emission and Interference Limits 2-7
2.4.6.1	Transmitter-Antenna System Emissions 2-8
2.4.6.2	Conducted and Radiated Interference 2-8
2.4.7	Operational Flexibility 2-8
2.4.8	Modulated Transmitter Bandwidth 2-8
2.5	UHF Telemetry Receiver System 2-9
2.5.1	Spurious Emissions 2-9
2.5.2	Frequency Tolerance 2-9
2.5.3	Receiver Phase Noise..... 2-9
2.5.4	Spurious Responses 2-10
2.5.5	Operational Flexibility 2-10
2.5.6	Intermediate Frequency Bandwidths..... 2-10
CHAPTER 3 - FREQUENCY DIVISION MULTIPLEXING	
TELEMETRY STANDARDS	3-1
3.1	General 3-1
3.2	FM Subcarrier Characteristics 3-1
3.3	FM Subcarrier Channel Characteristics 3-1
3.3.1	Proportional-Bandwidth FM Subcarrier Channel Characteristics 3-1
3.3.2	Constant-Bandwidth FM Subcarrier Channel Characteristics 3-5
3.4	Tape Speed Control and Flutter Compensation 3-5
CHAPTER 4 - PULSE CODE MODULATION STANDARDS.....	4-1
4.1	General 4-1
4.2	Class Distinctions and Bit-Oriented Characteristics 4-1
4.2.1	Class I and Class II Distinctions 4-1
4.2.2	Bit-Oriented Definitions and Requirements 4-2
4.2.2.1	Binary Bit Representation 4-2
4.2.2.2	Serial Bit Stream Transitions 4-2
4.2.2.3	Bit Rate 4-2
4.2.2.4	Bit Rate Accuracy and Stability 4-2
4.2.2.5	Bit Jitter..... 4-2
4.3	Fixed Formats 4-2
4.3.1	Word-Oriented Definitions and Requirements 4-2
4.3.1.1	Word Length (Class I and II) 4-2

	<u>Page</u>
4.3.1.2	Fragmented Words (Class II) 4-4
4.3.1.3	Bit Numbering 4-4
4.3.1.4	Word Numbering 4-4
4.3.2	Frame Structure..... 4-4
4.3.2.1	Minor Frame 4-4
4.3.2.1.1	Minor Frame Length (Class I and II) 4-4
4.3.2.1.2	Minor Frame Composition..... 4-4
4.3.2.1.3	Minor Frame Synchronization 4-4
4.3.2.1.4	Transmitted Frame Counter 4-4
4.3.2.2	Major Frame..... 4-6
4.3.2.2.1	Major Frame Length 4-6
4.3.2.2.2	Minor Frame Numbering 4-6
4.3.2.3	Subcommutation 4-6
4.3.2.3.1	Subframe 4-6
4.3.2.3.2	Subframe Synchronization Method 4-6
4.3.2.4	Supercommutation 4-6
4.4	Format Change (Class II)..... 4-6
4.4.1	Frame Format Identification 4-7
4.4.2	Format Change Implementation Methods..... 4-7
4.4.2.1	Measurement List Change 4-7
4.4.2.2	Format Structure Change 4-7
4.5	Asynchronous Embedded Format (Class II) 4-7
4.6	Tagged Data Format (Class II)..... 4-7
4.6.1	Alternating Tag and Data..... 4-7
4.6.2	Bus Data Military Standard (MIL-STD-1553)..... 4-7
4.7	Time Words 4-8
4.8	Asynchronous Data Merge..... 4-11
4.8.1	PCM Data Word Format..... 4-11
4.8.2	Insertion Process 4-11
4.8.2.1	Transmission Overhead 4-11
4.8.2.2	Parity Bit 4-11
4.8.2.3	Data Bits..... 4-11
4.8.2.4	Stale Data Bit 4-12
4.8.2.5	Overflow Bit 4-12
4.8.2.6	Insertion Rate 4-12
CHAPTER 5 - DIGITIZED AUDIO TELEMETRY STANDARD.	5-1
5.1	General 5-1
5.2	Definitions..... 5-1

		<u>Page</u>
5.2.1	Band-Limited Audio	5-1
5.2.2	Continuous Variable Slope Delta Modulation.....	5-1
5.3	Signal Source	5-1
5.4	Encoding/Decoding Technique.....	5-1
5.5	CVSD Encoder Output Bit Rate (CVSD Bit Rate).....	5-2
5.6	CVSD Word Structure	5-2
5.7	CVSD Word Sample Rate	5-2
5.8	CVSD Bit Rate Determination.....	5-3

CHAPTER 6 - MAGNETIC TAPE RECORDER AND REPRODUCER STANDARDS

		6-1
6.1	Introduction	6-1
6.2	Definitions.....	6-1
6.2.1	5/6 Modulation Code	6-1
6.2.2	Basic Dimension	6-1
6.2.3	Bias Signal, High Frequency.....	6-1
6.2.4	Bi-Phase	6-2
6.2.5	Bit Error	6-2
6.2.6	Bit Error Rate.....	6-2
6.2.7	Bit Packing Density, Linear	6-2
6.2.8	Bit Slip	6-2
6.2.9	Code Frame	6-2
6.2.10	Code Word Digital Sum (CWDS)	6-2
6.2.11	Crossplay.....	6-2
6.2.12	Crosstalk	6-2
6.2.13	Data Azimuth (Dynamic).....	6-2
6.2.14	Data Scatter	6-2
6.2.15	Data Spacing	6-2
6.2.16	Digital Sum Variation (DSV)	6-2
6.2.17	Direct Recording (ac Bias Recording)	6-3
6.2.18	Double-Density Recording.....	6-3
6.2.19	Dropout	6-3
6.2.20	ECC Code Word	6-3
6.2.21	Edge Margin	6-3
6.2.22	Edge Margin Minimum.....	6-3
6.2.23	Error Correcting Code.....	6-3
6.2.24	FM Recording	6-3
6.2.25	Flux Transition.....	6-3
6.2.26	Flux Transition Density	6-3
6.2.27	Flutter	6-3
6.2.28	Gap Azimuth.....	6-3
6.2.29	Gap Length (Physical).....	6-4

Page

6.2.30	Gap Scatter (Record Head)	6-4
6.2.31	Gap Scatter (Reproduce Head)	6-4
6.2.32	Guard Band	6-4
6.2.33	Head (Record or Reproduce)	6-4
6.2.34	Head Designation	6-4
6.2.35	Heads, In-Line	6-4
6.2.36	Head Reference Plane	6-4
6.2.37	Head Segment, Record or Reproduce	6-4
6.2.38	Head Segment Gap Azimuth (Record or Reproduce Heads).....	6-4
6.2.39	Head Segment Gap Azimuth Scatter	6-5
6.2.40	Head Segment Numbering	6-5
6.2.41	Head Spacing	6-5
6.2.42	Head Tilt	6-5
6.2.43	Heads, Interlaced.....	6-5
6.2.44	Helical Track.....	6-5
6.2.45	High-Density Digital Recording	6-5
6.2.46	Individual Track Data Azimuth Difference	6-5
6.2.47	Interleaving	6-5
6.2.48	Non-Return-To-Zero Level.....	6-5
6.2.49	Physical Recording Density	6-5
6.2.50	Principal Block.....	6-5
6.2.51	Principal Block Number (PBN)	6-6
6.2.52	Record Level Set Frequency	6-6
6.2.53	Reference Tape Edge	6-6
6.2.54	Reference Track Location.....	6-6
6.2.55	Scanner.....	6-6
6.2.56	Standard Record Level.....	6-6
6.2.57	Tape Skew.....	6-6
6.2.58	Tape Speed, Absolute	6-6
6.2.59	Tape Speed, Effective	6-6
6.2.60	Tape Speed Errors	6-6
6.2.61	Track Angle.....	6-6
6.2.62	Track Location	6-6
6.2.63	Track Numbering	6-7
6.2.64	Track Spacing	6-7
6.2.65	Track Width	6-7
6.2.66	Volume Label.....	6-7
6.3	General Consideration for Longitudinal Recording.....	6-7
6.3.1	Tape Speeds	6-7
6.3.2	Tape Width.....	6-7
6.3.3	Record and Reproduce Bandwidths	6-7
6.4	Recorded Tape Format.....	6-7

	<u>Page</u>
6.4.1	Track Width and Spacing..... 6-7
6.4.2	Track Numbering 6-16
6.4.3	Data Spacing 6-16
6.4.4	Head Placement 6-16
6.4.4.1	Head Placement, Interlaced..... 6-16
6.4.4.2	Head Identification and Location..... 6-16
6.4.4.3	In-Line Head Placement..... 6-16
6.4.4.4	Head Segment Location 6-16
6.5	Head and Head Segment Mechanical Parameters 6-16
6.5.1	Gap Scatter 6-16
6.5.2	Head Segment Gap Azimuth Alignment 6-17
6.5.3	Head Tilt 6-17
6.5.4	Record-Head Segment Gap Parameters 6-17
6.5.4.1	Record-Head Segment Gap Length 6-17
6.5.4.2	Record-Head Stack Gap Azimuth Alignment..... 6-17
6.5.4.3	Reproduce-Head Segment Gap Azimuth Alignment..... 6-17
6.6	Head Polarity..... 6-17
6.6.1	Record-Head Segment 6-17
6.6.2	Reproduce-Head Segment..... 6-17
6.7	Magnetic Tape and Reel Characteristics..... 6-18
6.7.1	Tape Width..... 6-18
6.7.2	Tape Guiding 6-18
6.8	Direct Record and Reproduce Systems..... 6-18
6.8.1	Direct Record Parameters 6-18
6.8.2	Standard Record Level..... 6-19
6.8.3	Reproduce Parameters..... 6-19
6.8.4	Tape Speed and Flutter Compensation 6-19
6.9	Timing, Predetection, and Tape Signature Recording 6-20
6.9.1	Timing Signal Recording 6-20
6.9.2	Predetection Recording 6-20
6.9.3	Tape Signature Recording..... 6-20
6.10	FM Record Systems 6-22
6.10.1	Tape and Reel Characteristics..... 6-22
6.10.2	Tape Speeds and Corresponding FM Carrier Frequencies 6-22
6.10.3	FM Record/Reproduce Parameters 6-22
6.10.4	Speed Control and Compensation..... 6-24
6.10.5	FM Record Parameters..... 6-24
6.10.5.1	Deviation Direction..... 6-24
6.10.6	FM Reproduce Systems 6-24
6.11	PCM Recording 6-24
6.11.1	Predetection PCM Recording 6-24
6.11.2	Post-Detection PCM Recording..... 6-24
6.11.3	Serial High Density Digital Recording 6-25

	<u>Page</u>
6.11.4.1	PCM Codes 6-25
6.11.4.2	Bi ϕ -L Code..... 6-26
6.11.4.3	RNRZ-L Code..... 6-26
6.11.4.4	Record Parameters 6-28
6.11.4.5	Reproduce Parameters..... 6-28
6.11.4.5.1	PCM Signature..... 6-28
6.11.4.5.2	Phase Equalizer 6-28
6.11.4.6	Magnetic Tape..... 6-28
6.11.4.7	Tape Copying 6-28
6.11.4.8	PCM Bit Synchronizer 6-29
6.12	Preamble Recording for Automatic or Manual Recorder Alignment
6.12.1	Alignment, Direct Electronics..... 6-29
6.12.2	Alignment, FM Electronics..... 6-29
6.13	19-mm Digital Cassette Helical Scan Recording Standards..... 6-29
6.13.1	Track Format 6-30
6.13.2	Tape and Cassettes 6-30
6.13.3	Recorder/Reproducer Input and Output..... 6-30
6.14	Multiplex/Demultiplex (MUX/DEMUX) Standard for Multiple Data Channel Recording on 19-MM Digital Cassette Helical Scan Recorder/Reproducer Systems 6-32
6.15	Submultiplex/Demultiplex Standards for Multiple Data Channels on a Primary Digital Multiplex/Demultiplex Channel 6-34
6.15.1	Format Structure 6-35
6.15.2	Implied Parameters and Limits 6-35
6.15.3	Defined Parameters 6-36
6.15.4	Aggregate Format on the Primary Data Channel 6-37
6.15.5	Submux/Demux FILL Requirements..... 6-37
6.16	1/2 Inch Digital Cassette (S-VHS) Helical Scan Recording Standards..... 6-40
6.16.1	Tape and Tape Cartridge..... 6-40
6.16.2	Format Types 6-40
6.16.2.1	B Format 6-40
6.16.2.2	E Format..... 6-40
6.16.3	Data Storage..... 6-42
6.16.4	Physical Relationships 6-42
6.16.5	Helical Track Organization..... 6-42
6.16.6	Recorded Information 6-42
6.16.7	Recording Geometry and Physical Dimensions..... 6-43
6.16.7.1	Tape Reference Edge 6-43
6.16.7.2	Helical Tracks 6-43
6.16.7.2.1	Track Widths..... 6-43

	<u>Page</u>
6.16.7.2.2	Track Pitch 6-43
6.16.7.2.3	Track Straightness 6-43
6.16.7.2.4	Gap Azimuths 6-43
6.16.7.2.5	Track Guard Bands 6-44
6.16.7.2.6	Track Angle 6-44
6.16.7.2.7	Track Length 6-44
6.16.7.2.8	Physical Recording Density 6-44
6.16.7.3	Longitudinal Tracks 6-44
6.16.7.3.1	Servo Track 6-44
6.16.7.3.2	Filemark Track 6-44
6.16.8	Tape Cartridge Format 6-46
6.16.8.1	Load Point 6-46
6.16.8.2	Format Zone 6-46
6.16.8.3	Logical Beginning of Tape 6-46
6.16.8.4	Data Zone 6-46
6.16.8.5	Logical End of Tape 6-46
6.16.9	Helical Track Format 6-47
6.16.9.1	Sync Patterns 6-48
6.16.9.2	Data Blocks 6-48
6.16.9.2.1	Error Correction Encoding 6-48
6.16.9.2.2	Interleave Buffer 6-50
6.16.9.2.2.1	Exchange of Data with ECC 6-50
6.16.9.2.2.2	Exchange of Data To and From Tape 6-52
6.16.9.2.3	8 to 5 Conversion 6-54
6.16.9.2.4	Miscellaneous Information Inclusion 6-54
6.16.9.2.5	Modulation Code 6-56
6.17	Multiplex/Demultiplex (MUX/DEMUX) Standards for Multiple Data Channel Recording on ½ Inch Digital Cassette (S-VHS) Helical Scan Recorder/Reproducer System 6-56
6.17.1	General 6-56
6.17.2	Setup Block Format 6-56
6.17.3	Multiplexer Format 6-57
6.17.3.1	Frame Structure 6-57
6.17.3.2	Pacer Divisor Calculation 6-58
6.17.3.3	ARMOR Channel Coding 6-59
6.17.3.4	Sync Pattern 6-59
6.17.3.5	Time Code Channels 6-59
6.17.3.6	PCM Channels 6-60
6.17.3.7	Analog Channels 6-61
6.17.3.8	Parallel Channels 6-61
6.17.4	ARMOR Format Compatibility 6-61
6.17.5	ARMOR Format Validation 6-62

	<u>Page</u>
CHAPTER 7 - MAGNETIC TAPE STANDARDS	7-1
7.1 General	7-1
7.2 Definitions.....	7-1
7.2.1 Back Coating.....	7-1
7.2.2 Base.....	7-1
7.2.3 Bias Level	7-2
7.2.4 Bi-Directional	7-2
7.2.5 Binder.....	7-2
7.2.6 Blocking.....	7-2
7.2.7 Center Tracks	7-2
7.2.8 Dropout	7-2
7.2.9 Edge Tracks.....	7-2
7.2.10 Erasure	7-2
7.2.11 E-Value	7-2
7.2.12 High-Density Digital Magnetic Tape.....	7-2
7.2.13 High-Energy Magnetic Tape.....	7-2
7.2.14 High-Resolution Magnetic Tape.....	7-3
7.2.15 Layer-to-Layer Signal Transfer (Print Through).....	7-3
7.2.16 Magnetic Oxide Coating	7-3
7.2.17 Manufacturer's Centerline Tape	7-3
7.2.18 Manufacturer's Secondary Centerline Tape	7-3
7.2.19 Modulation Noise.....	7-3
7.2.20 Record Level	7-3
7.2.21 Scatterwind	7-3
7.2.22 Shedding	7-3
7.2.23 Short Wavelength Output Uniformity	7-4
7.2.24 Upper Band Edge	7-4
7.2.25 Wavelength Response	7-4
7.2.26 Working Length	7-4
7.2.27 Working Reference Tape	7-4
7.3 General Requirements for Standard Tapes and Reels.....	7-4
7.3.1 Reference Tape System.....	7-4
7.3.1.1 Manufacturer's Centerline Tape	7-4
7.3.1.2 Manufacturer's Secondary Centerline Tape	7-4
7.3.1.3 Working Reference Tape	7-5
7.3.1.4 Test Recorder and Reproducer.....	7-5
7.3.1.5 MCT/MSCT/WRT Use.....	7-5
7.3.2 Marking and Identifying.....	7-5
7.3.3 Packaging.....	7-5
7.3.4 Winding.....	7-5

	<u>Page</u>
7.3.5	Reels and Hubs 7-5
7.3.6	Radial Clearance (E-Value) 7-5
7.3.7	Flammable Materials 7-5
7.3.8	Toxic Compounds 7-5
7.4	General Characteristics of Tapes and Reels..... 7-6
7.4.1	Dimensional Specifications 7-6
7.4.2	Environmental Conditions 7-7
7.4.2.1	Tape Storing Conditions 7-7
7.4.2.2	Operating Environment..... 7-7
7.4.2.3	Non-operating Environment 7-7
7.4.3	Other Characteristics..... 7-8
7.5	Physical Characteristics of Instrumentation Tapes and Reels..... 7-8
7.6	Instrumentation Tape Magnetic and Electrical Characteristics 7-8
7.6.1	Bias Level 7-8
7.6.2	Record Level 7-8
7.6.3	Wavelength Response 7-8
7.6.4	Output at 0.1 UBE Wavelength 7-9
7.6.5	Short Wavelength Output Uniformity..... 7-9
7.6.6	Dropouts..... 7-9
7.6.7	Durability 7-10
7.6.8	Modulation Noise..... 7-11
7.6.9	Layer-to-Layer Signal Transfer 7-11
7.6.10	Erase Ease..... 7-14
7.6.11	Suggested Tape Requirement Limits 7-14
7.7	General Requirements for 19-mm Digital Cassette Helical Scan Recording Tape and Cassettes 7-14
7.7.1	Magnetic Tape..... 7-14
7.7.2	19-mm Cassettes 7-14
7.8	General Requirements for 1/2-Inch Digital Cassette Helical Scan Recording Tape and Cassettes 7-14
7.8.1	Magnetic Tape..... 7-14
7.8.2	1/2-Inch Cassettes 7-14
 CHAPTER 8 - MIL-STD-1553 ACQUISITION FORMATTING	
	STANDARD 8-1
8.1	General 8-1
8.2	Definitions..... 8-1
8.2.1	Bus Monitor 8-1
8.2.2	Data Bus 8-1
8.2.3	Dual Redundant Data Bus..... 8-1
8.2.4	Bus Loading 8-1

		<u>Page</u>
8.2.5	Maximum Burst Length.....	8-1
8.2.6	Bus Error.....	8-1
8.3	Source Signal.....	8-2
8.4	Word Structure.....	8-2
8.5	Time Words.....	8-5
8.6	Composite Output.....	8-5
8.7	Single Bus Track Spread Recording Format.....	8-6

CHAPTER 9 - TELEMETRY ATTRIBUTES TRANSFER

	STANDARD.....	9-1
9.1	General.....	9-1
9.2	Scope.....	9-1
9.3	Purpose.....	9-1
9.4	Media and Data Structure.....	9-2
9.4.1	Physical Format.....	9-2
9.4.2	Logical Format.....	9-2
9.5	Telemetry Attributes.....	9-3
9.5.1	Contents.....	9-4
9.5.1.1	Organization.....	9-4
9.5.1.2	Group Relationships.....	9-5
9.5.2	General Information (G).....	9-7
9.5.3	Transmission Attributes (T).....	9-10
9.5.4	Tape Source Attributes (R).....	9-15
9.5.5	Multiplex/Modulation Attributes (M).....	9-20
9.5.6	Digital Data Attributes.....	9-25
9.5.6.1	PCM Format Attributes (P).....	9-25
9.5.6.2	PCM Measurement Description (D).....	9-39
9.5.6.3	1553 Bus Data Attributes (B).....	9-50
9.5.7	PAM Attributes (A).....	9-57
9.5.8	Data Conversion Attributes (C).....	9-60
9.5.9	Airborne Hardware Attributes (H).....	9-71

APPENDIX A - FREQUENCY CONSIDERATIONS FOR TELEMETRY.....

		A-1
1.0	Purpose.....	A-2
2.0	Scope.....	A-2
2.1	Definitions.....	A-2
2.2	Other Notations.....	A-3
3.0	Authorization to Use a Telemetry System.....	A-3
3.1	RF Spectrum Support Certification.....	A-3
3.1.1	Frequency Allocation.....	A-4

Page

3.1.1.1	Telemetry Bands	A-4
3.1.1.2	VHF Telemetry	A-4
3.1.2	Technical Standards	A-4
3.2	Frequency Authorization.....	A-4
4.0	Frequency Usage Guidance.....	A-5
4.1	Frequency Assignments	A-5
4.2	Geographical Separation	A-5
4.3	Simultaneous Operation.....	A-6
4.4	Multicarrier Operation	A-6
4.5	Transmitter Antenna System Emission Testing.....	A-6
5.0	Bandwidth	A-6
5.1	Concept	A-7
5.1.1	Authorized Bandwidth.....	A-7
5.1.2	Occupied Bandwidth.....	A-7
5.1.3	Necessary Bandwidth.....	A-7
5.1.4	Received (or Receiver) Bandwidth	A-8
5.2	Bandwidth Estimation and Measurement	A-8
5.2.1	99-Percent Power Bandwidth.....	A-8
5.2.2	-25 dBm Bandwidth	A-10
5.2.3	Other Bandwidth Measurement Methods	A-10
5.2.3.1	Below Unmodulated Carrier	A-10
5.2.3.2	Below Peak	A-11
5.2.3.3	Carson's Rule	A-12
5.2.4	Spectral Equations	A-12
5.2.5	Receiver Bandwidth.....	A-14
5.2.6	Receiver Noise Bandwidth.....	A-14
5.3	Phase-Modulated Systems	A-14
5.4	Symmetry	A-15
5.5	FM Transmitters (ac coupled).....	A-15
6.0	Spectral Occupancy Limits	A-15
6.1	Spectral Mask.....	A-15
6.2	Spectral Mask Examples.....	A-17
7.0	FQPSK-B Characteristics	A-18

APPENDIX B - USE CRITERIA FOR FREQUENCY DIVISION		
	MULTIPLEXING	B-1
1.0	General.....	B-2
2.0	FM Subcarrier Performance.....	B-2
3.0	FM Subcarrier Performance Tradeoffs	B-3
4.0	FM System Component Considerations	B-4
5.0	Range Capability for FM Subcarrier Systems	B-5

		<u>Page</u>
5.1	Receivers and Tape Recorders	B-5
5.2	Discriminator Channel Selection Filters	B-5

APPENDIX C - PCM STANDARDS C-1

1.0	Bit Rate Versus Receiver Intermediate-Frequency Bandwidth.....	C-2
2.0	Recommended PCM Synchronization Patterns	C-3
3.0	Spectral and BEP Comparisons for NRZ and Biφ	C-3
4.0	PCM Frame Structure Examples	C-6

**APPENDIX D - MAGNETIC TAPE RECORDER AND REPRODUCER
INFORMATION AND USE CRITERIA** D-1

1.0	Other Instrumentation Magnetic Tape Recorder Standards.....	D-2
2.0	Double-Density Longitudinal Recording	D-3
2.2.1	Other Track Configurations	D-3
2.2.2	High-Density PCM Recording.....	D-3
3.0	Serial HDDR.....	D-9
3.9	Randomizer for RNRZ-L.....	D-11
4.0	Head Parameters	D-17
4.1	Gap Scatter	D-17
4.2	Head Polarity.....	D-17
5.0	Record Level.....	D-17
6.0	Tape Crossplay Considerations.....	D-18
7.0	Standard Tape Signature Procedures	D-18
7.1	PCM Signature Recording Procedures	D-18
7.2	PCM Signature Playback Procedure	D-20
7.3	Swept Frequency Signature Recording Procedure.....	D-20
7.4	Swept Frequency Signature Playback Procedure.....	D-21
8.0	Equipment Required for Swept-Frequency Procedures	D-21
9.0	Fixed-Frequency Plus White Noise Procedure	D-22
10.0	Signature Playback and Analysis	D-23
11.0	Recording and Playback Alignment Procedures.....	D-23
11.1	Recording of Preamble for Direct Electronics Alignment.....	D-23
11.2	Playback of Preamble for Direct Electronics Alignment	D-24
11.3	Recording of Preamble for FM Electronics Alignment	D-25
11.4	Playback of Preamble for FM Electronics Alignment	D-25

**APPENDIX E – AVAILABLE TRANSDUCER DOCUMENTATION
Intentionally Deleted** E-1

APPENDIX F - CONTINUOUSLY VARIABLE SLOPE DELTA MODULATION		F-1
1.0	General	F-2
2.0	General Descriptions	F-2
2.1	Delta Modulation	F-2
2.2	CVSD Converter	F-2
3.0	Detailed Descriptions	F-4
3.1	Input Band Pass Filter	F-4
3.2	Comparator	F-4
3.3	3-Bit Shift Register	F-4
3.4	Overload Algorithm	F-4
3.5	Syllabic Filter	F-5
3.6	Pulse Amplitude Modulator (PAM).....	F-5
3.7	Reconstruction Integrator.....	F-5
3.8	Output Low-Pass Filter	F-5
3.9	Typical CVSD Decoder Output Envelope Characteristics	F-5
4.0	Reference Level	F-6
5.0	CVSD Characteristics	F-6
5.1	Input and Output Impedances	F-6
5.2	Data Signaling Rates	F-6
5.3	Input and Output Filters	F-6
5.4	Overload Algorithm	F-7
5.5	Compression Ratio.....	F-7
5.6	Syllabic Filter	F-7
5.7	Reconstruction Integrator Time Constant	F-7
5.8	Analog-to-Digital Conversion.....	F-7
5.9	Digital-to-Analog Conversion.....	F-7
5.9.1	Relation of Output to Input	F-7
5.9.2	Conversion Speed	F-7
5.10	CVSD Converter Performance.....	F-7
5.10.1	Companding Speed	F-8
5.10.2	Insertion Loss	F-8
5.10.3	Insertion Loss Versus Frequency Characteristics	F-8
5.10.4	Variation of Gain With Input Level	F-10
5.10.5	Idle Channel Noise.....	F-10
5.10.6	Variation of Quantizing Noise With Input Level.....	F-10
5.10.7	Variation of Quantizing Noise With Frequency	F-10

	<u>Page</u>
APPENDIX G - ADARIO DATA BLOCK FIELD DEFINITIONS	G-1
ADARIO Data Format Field Definitions Summary	G-6
APPENDIX H - APPLICATION OF THE TELEMETRY ATTRIBUTES TRANSFER STANDARD	H-1
APPENDIX I - TELEMETRY ATTRIBUTES TRANSFER STANDARD COVER SHEET	I-1
APPENDIX J - TELEMETRY ATTRIBUTES TRANSFER STANDARD FORMAT EXAMPLE	J-1
APPENDIX K - PULSE AMPLITUDE MODULATION STANDARDS	K-1
1.0 General	K-2
2.0 Frame and Pulse Structure	K-2
2.1.1 Commutation Pattern	K-2
2.1.2 In-Flight Calibration	K-2
2.1.3 Frame Synchronization Interval	K-2
2.1.3.1 Fifty Percent Duty Cycle (RZ-PAM)	K-2
2.1.3.2 One Hundred Percent Duty Cycle (NRZ-PAM)	K-4
2.1.4 Maximum Pulse Rate	K-4
2.1.4.1 PAM/FM/FM	K-4
2.1.4.2 PAM/FM	K-4
2.2 Frame and Pulse Rate	K-4
2.2.1 Long Term Accuracy and Stability	K-4
2.2.2 Short Term Stability	K-4
2.3 Multiple and Submultiple Sampling Rates	K-4
2.3.1 Submultiple Frame Synchronization	K-4
2.3.1.1 Fifty Percent Duty Cycle (RZ)	K-5
2.3.1.2 One Hundred Percent Duty Cycle (NRZ)	K-5
2.3.2 Maximum Submultiple Frame Length	K-5
2.4 Frequency Modulation	K-5
2.5 Premodulation Filtering	K-5
APPENDIX L – ARMOR	L-1
1.0 General	L-2
1.1 Setup on Tape	L-2

Page

2.0	Setup Organization.....	L-3
2.1	Header Section	L-3
2.2	Channel Section	L-5
2.3	Trailer Section.....	L-15
2.4	Saved Scan-list Structure	L-16
2.5	Creating a Setup Block	L-16
2.5.1	Header Section	L-17
2.5.2	Channel Section	L-17
2.5.2.1	PCM Input Channels.....	L-17
2.5.2.2	Analog Input Channels.....	L-17
2.5.2.3	Parallel Input Channels	L-18
2.5.2.4	Time Code Input Channels	L-18
2.5.2.5	Voice Input Channels.....	L-18
2.5.3	Trailer Section.....	L-18
2.5.4	ARMOR Compiler Program.....	L-18

LIST OF FIGURES

<u>Figure No.</u>		<u>Page</u>
2-1	Continuous single sideband phase noise power spectral density	2-7
4-1	PCM code definitions	4-3
4-2	PCM frame structure.....	4-5
4-3	16 bit standardized time word format	4-9
4-4	Time word insertion into 12 bit PCM word size	4-10
4-5	Asynchronous word structure	4-12
4-6	Overhead truth table.....	4-12
5-1	Insertion of CVSD encoded audio into a PCM stream	5-2
6-1	Recorded tape format.....	6-12
6-2	Record and reproduce head and head segment identification and location (N-track interlaced system)	6-13
6-3	Head and head segment mechanical parameters	6-14
6-4	PCM record and reproduce configuration.....	6-15
6-5	Serial high density digital record and reproduce.....	6-27
6-6	Location and dimensions of recorded tracks.....	6-30
6-7	ADARIO block format.....	6-33
6-8	ADARIO data format.....	6-34
6-9a	Submux data format.....	6-38
6-9b	Submux data format.....	6-39
6-10	Helical track dimensions, B format.....	6-41
6-11	Helical track dimensions, E format.....	6-41

<u>Figure No.</u>		<u>Page</u>
--------------------------	--	--------------------

6-12	Recorded tracks on tape, B format.....	6-45
6-13	Tape cartridge layout.....	6-46
6-14	Helical track format	6-47
6-15	Typical VLDS data path electronics block diagram	6-49
6-16	Interleave buffer architectures.....	6-51
6-17	The steps of the build process	6-57
8-1	System block diagram.....	8-2
8-2	Word construction.....	8-4
8-3	Composite frame structure.....	8-7
8-4	Multiple tape track spread format (4-track spread example)	8-8
9-1	Group relationships.....	9-6
9-2	General Information Group (G).....	9-7
9-3	Transmission Attributes Group (T).....	9-11
9-4	Tape Source Attributes Group (R).....	9-16
9-5	Multiplex/Modulation Attributes Group (M)	9-21
9-6	PCM Format Attributes Group (P)	9-26
9-7	PCM Measurement Description Group (D).....	9-40
9-8	1553 Bus Data Attributes Group (B)	9-51
9-9	PAM Attributes Group (A).....	9-57
9-10	Data Conversion Attributes Group (C).....	9-61
A-1	800-kb/s and 5-Mb/s RNRZ PCM/FM signals	A-5
A-2	RNRZ PCM/FM signal.....	A-10
A-3	Spectrum analyzer calibration of 0-dBc level.....	A-11
A-4	Bi ϕ PCM/PM signal.....	A-11
A-5	FM/FM signal and Carson's Rule	A-12
A-6	Typical receiver IF filter response (-3 dB bandwidth = 1 MHz)	A-14
A-7	Filtered 1-Mb/s RNRZ PCM/FM signal and spectral mask	A-17
A-8	Unfiltered 1-Mb/s RNRZ PCM/FM signal and spectral mask	A-17
A-9	Typical 1-Mb/s FQPSK-B signal and spectral mask	A-17
A-10	OQPSK modulator.....	A-18
A-11	I & Q constellation.....	A-18
A-12	FQPSK-B wavelets	A-19
A-13	FQPSK-B I & Q eye diagrams (at input to IQ modulator)	A-19
A-14	FQPSK-B vector diagram	A-19
A-15	FQPSK-B spectrum with random input data	A-20
A-16	FQPSK-B spectrum with all 1's input and large modulator errors....	A-20
A-17	FQPSK-B BEP vs E_b/N_0	A-21
C-1	BEP versus IF SNR in bandwidth = bit rate for NRZ-L PCM/FM.....	C-2
C-2	Spectral densities of random NRZ and Bi ϕ codes	C-6

<u>Figure No.</u>		<u>Page</u>
C-3	Theoretical bit error probability performance for various baseband PCM signaling techniques (perfect bit synchronization assumed)	C-7
C-4	Major frame length = minor frame maximum length	C-8
C-5	Major frame length = minor frame maximum length multiplied by Z.....	C-9
C-6	Major frame length = minor frame maximum length multiplied by Z.....	C-10
D-1	Record and reproduce head and head segment identification and location (7-track interlaced system).....	D-4
D-2	Randomizer block diagram	D-12
D-3	Randomized NRZ-L decoder block diagram	D-13
D-4	Random PCM power spectra	D-15
D-5	Sample eye patterns at output of recorder/reproducer	D-16
D-6	Tape crossplay.....	D-19
D-7	Square wave responses.....	D-25
F-1a	Typical CVSD encoder	F-3
F-1b	Typical CVSD decoder	F-3
F-2	Typical envelope characteristics of the decoder output signal for CVSD.....	F-6
F-3	Interface diagram for CVSD converter	F-8
F-4a	Insertion loss versus frequency for CVSD (16 kbps).....	F-9
F-4b	Insertion loss versus frequency for CVSD (32 kbps).....	F-10
F-5a	Variation of gain with input level for CVSD (16 kbps).....	F-11
F-5b	Variation of gain with input level for CVSD (32 kbps).....	F-11
F-6a	Signal to quantizing noise ratio versus input level for CVSD (16 kbps).....	F-12
F-6b	Signal to quantizing noise ratio versus input level for CVSD (32 kbps).....	F-12
F-7a	Signal to quantizing noise ratio versus frequency for CVSD (16 kbps).....	F-13
F-7b	Signal to quantizing noise ratio versus frequency for CVSD (16 kbps).....	F-13
G-1	ADARIO data format.....	G-3
G-2	ADARIO data blocks	G-4
G-3	ADARIO timing.....	G-5
G-4a	Submux data format.....	G-20
G-4b	Submux data format.....	G-21
G-5	Submux aggregate format	G-22
H-1	Typical elements of the telemetry attributes transfer process.....	H-3
J-1	Group linkages	J-3

J-2	PCM format for PCM w/async	J-6
J-3	PCM format for PCM1	J-7
J-4	PCM format for async	J-8
K-1	50-percent duty cycle PAM with amplitude synchronization	K-3
K-2	100-percent duty cycle PAM with amplitude synchronization	K-3

LIST OF TABLES

<u>Table No.</u>		<u>Page</u>
2-1	FQPSK-B Phase Map	2-6
2-2	Standard Receiver IF Bandwidths.....	2-10
3-1	Proportional-Bandwidth FM Subcarrier Channels	3-2
3-2	Constant-Bandwidth FM Subcarrier Channels	3-6
3-3	Reference Signal Usage	3-7
6-1	Record and Reproduce Parameters	6-8
6-2	Dimensions - Recorded Tape Format, 14 Tracks Interlaced on 25.4 mm (1 in.) Wide Tape	6-9
6-3	Dimensions - Recorded Tape Format, 14 Tracks In-Line on 25.4 mm (1 in.) Wide Tape	6-10
6-4	Dimensions - Recorded Tape Format, 28 Tracks Interlaced on 25.4 mm (1 in.) Wide Tape	6-11
6-5	Constant-Amplitude Speed-Control Signals.....	6-21
6-6	Predetection Carrier Parameters.....	6-22
6-7	Wide-Band and Double-Density FM Record Parameters.....	6-23
6-8	Maximum Recommended Bit Rates, Post-Detection Recording	6-25
6-9	Maximum Recommended Bit Rates	6-26
6-10	Record Location and Dimensions	6-31
6-11	Tape Length and Nominal Play Record/Reproduce Time at 240 Megabits/Second User Data Rate	6-31
6-12	Scanlist build steps.....	6-58
6-13	Sample armor frame.....	6-59
6-14	Time code word format.....	6-60
7-1	Tape Dimensions	7-6
7-2	Measurement Wavelengths	7-9
7-3	Durability Signal Losses	7-11
7-4	Suggested Tape Requirement Limits	7-12
7-4A	Suggested Wavelength Response Requirements	7-13
9-1	General Information Group (G)	9-8
9-2	Transmission Attributes Group (T).....	9-12
9-3	Tape Source Attributes Group (R)	9-17

<u>Table No.</u>		<u>Page</u>
9-4	Multiplex/Modulation Group (M)	9-22
9-5	PCM Format Attributes Group (P)	9-28
9-6	PCM Measurement Description Group (D)	9-42
9-7	1553 Bus Data Attributes Group (B)	9-52
9-8	PAM Attributes Group (A)	9-58
9-9	Data Conversion Attributes Group (C)	9-63
A-1	99% Power Bandwidths for Various Digital Modulation Methods	A-9
C-1	Optimum Frame Synchronization Patterns for PCM Telemetry	C-5
D-1	Dimensions - Recorded Tape Format, 7-Tracks Interlaced on 12.7-mm (1/2 in.) Wide Tape.....	D-5
D-2	Dimensions - Recorded Tape Format, 14-Tracks Interlaced on 12.7-mm (1/2 in.) Wide Tape.....	D-6
D-3	Dimensions - Recorded Tape Format, 42-Tracks Interlaced on 25.4-mm (1 in.) Wide Tape.....	D-7
F-1	Decoder Reference Digital Patterns for CVSD.....	F-8
F-2	Insertion Loss Limits for CVSD	F-9
F-3	Idle Channel Noise Limits for CVSD	F-12
L-1	ARMOR Setup Preamble.....	L-2
L-2	Setup Organization.....	L-3
L-3	Header Section Format.....	L-4
L-4	Channel Entry Lengths.....	L-5
L-5	PCM Input Channels	L-6
L-6	Analog Input and Output Channels.....	L-7
L-7	Analog Input and Output Channels.....	L-8
L-8	Parallel Input Channels	L-9
L-9	Parallel Output Channels	L-10
L-10	Time Code Input Channels	L-11
L-11	Time Code Output Channels.....	L-12
L-12	Voice Input Channel	L-13
L-13	Voice Output Channels	L-14
L-14	Bit Sync Input Channels.....	L-15
L-15	Trailer Section Format	L-16

INDEX

ACRONYMS AND INITIALISMS

ADARIO	Analog/Digital/Adaptable/Recorder Input/Output
AFC	automatic frequency control
AFTRCC	Aerospace and Flight Test Radio Coordinating Council
AGC	automatic gain control
ALC	automatic level control
AM	amplitude modulation
APC	automatic phase control
ARMOR	Asynchronous Real-time Multiplexer and Output Reconstructor
AWGN	additive white Gaussian noise
BCD	binary coded decimal
BEP	bit error probability
BER	bit error rate
BiØ-L	bi-phase level
BM	block marker
BMD	block marker division
pbs	bits per second
BRC	block rate clock
BW	bandwidth
CHP	channel parameter
CPFSK	continuous phase frequency shift keying
CR	carriage return
CSR	clock slip rate
CVSD	continuous variable slope delta
CW	continuous wave
CWDS	code word digital sum
dBm	decibels referenced to 1 milliwatt
DOD	Department of Defense
DSB	double sideband
DSV	digital sum variation
ECC	error correction coding
ENR	excess noise ratio
EOF	end of file
EIRP	effective isotropic radiated power
FCC	Federal Communications Commission
FDM	frequency division multiplex
FET	field effect transistor

ACRONYMS AND INITIALISMS

FFI	frame format identification
FM	frequency modulation
FMG	Frequency Management Group
FQPSK	Feher's-patented quadrature phase shift keying
GF	Galois field
G/T	gain/temperature
HDD	high density digital
HDDR	high density digital recording
HE	high energy
HR	high resolution
IF	intermediate frequency
IM	intermodulation
IMD	intermodulation distortion
IP	intercept point
ips	inches per second
IRAC	Interdepartmental Radio Advisory Committee
IRIG	Interrange Instrumentation Group
ITDE	interchannel time displacement error
ITU	International Telecommunications Union
kHz	kilohertz
ks	kiloseconds
LBOT	logical beginning of tape
LEOT	logical end of tape
LF	line feed
LIFO	last in first out
LO	local oscillator
log	logarithm
LSB	least significant bit
Mbps	megabits per second
MC	master clock
MCEB	Military Communications-Electronics Board
MCS	master clock source
MCT	manufacturer's centerline tape
MGC	manual gain control
MHz	megahertz
MIL STD	military standard

ACRONYMS AND INITIALISMS

MSB	most significant bit
MSCT	manufacturer's secondary centerline tape
MSK	minimum shift keying
N	newton
NNT	notch noise test
NPR	noise power ratio
NPRF	noise power ratio floor
NRZ	non-return-to-zero
NRZ-L	non-return-to-zero-level
NTIA	National Telecommunications and Information Administration
OQPSK	offset quadrature phase shift keying
PBOT	physical beginning of tape
PEOT	physical end of tape
p-p	peak-to-peak
PAM	pulse-amplitude modulation
PB	principal block
PCM	pulse-code modulation
PLL	phase-lock loop
PM	phase modulation
PRN	pseudo random noise
PSD	power spectral density
PSK	phase shift keying
PW	partial word
PWS	partial word status
QPSK	quadrature phase shift keying
R	bit rate
RCC	Range Commanders Council
RF	radio frequency
RH	relative humidity
rms	root mean square
RNRZ	randomized non-return-to-zero
RNRZ-L	randomized non-return-to-zero-level
RS	Reed-Solomon
SNR	signal-to-noise ratio
SSB	single sideband
SST	session start time

ACRONYMS AND INITIALISMS

ST	subterminal
STA	subterminal address
SWR	standing wave ratio
TBE	time base error
TC	tachometer constant
TD	time delay
TMATS	Telemetry Attributes Transfer Standard
TTL	transistor-transistor logic
UBE	upper band edge
UHF	ultra high frequency
US&P	United States and Possessions
VCO	voltage controlled oscillator
VHF	very high frequency
VLDS	very large data store
WARC-92	World Administrative Radio Conference - 1992
WC	word count

CHAPTER 1

INTRODUCTION PART I



Part 1 of the Telemetry Standards addresses the here-to-date conventional methods, techniques, and practices affiliated with aeronautical telemetry applicable to the member RCC ranges.

Part 1 of this document is composed of nine chapters; each devoted to a different element of the telemetry system or process.

Reference documents are identified at the point of reference.

Commonly used terms are defined in standard reference glossaries and dictionaries. Definitions of terms with special applications are included when the term first appears, generally in the front sections of individual chapters. Radio frequency terms are defined in the *Manual of Regulations and Procedures for Federal Radio Frequency Management*. Copies of that manual may be obtained from:

Executive Secretary, IRAC
U.S. Department of Commerce, NTIA
Room 1605, HCHB Building
14th and Constitution Avenue, N.W.
Washington, D.C. 20230

CHAPTER 2

TRANSMITTER AND RECEIVER SYSTEMS

2.1 Radio Frequency Standards for Telemetry

These standards provide the criteria to determine equipment and frequency use requirements and are intended to ensure efficient and interference-free use of the radio frequency spectrum and interchange of operations and data between test ranges. The radio frequency spectrum is a limited natural resource; therefore, efficient use of available spectrum is mandatory. In addition, susceptibility to interference must be minimized. Systems not conforming to these standards require justification upon application for frequency allocation, and the use of such systems is highly discouraged. The standards contained herein are derived from the National Telecommunications and Information Administration's (NTIA) Manual of Regulations and Procedures for Federal Radio Frequency Management.

2.2 Definitions

Allocation (of a Frequency Band). Entry of a frequency band into the Table of Frequency Allocations¹ for use by one or more radio communication services or the radio astronomy service under specified conditions.

Assignment (of a Radio Frequency or Radio Frequency Channel). Authorization given by an administration for a radio station to use a radio frequency or radio frequency channel under specified conditions.

Authorization. Permission to use a radio frequency or radio frequency channel under specified conditions.

Occupied Bandwidth. The width of a frequency band such that below the lower and above the upper frequency limits, the mean powers emitted are each equal to a specified percentage of the total mean power of a given emission. Unless otherwise specified by the International Telecommunication Union (ITU) for the appropriate class of emission, the specified percentage shall be 0.5 percent. The occupied bandwidth is also called the 99-percent power bandwidth in this document.

¹The definitions of the radio services that can be operated within certain frequency bands contained in the radio regulations as agreed to by the member nations of the International Telecommunications Union. This table is maintained in the United States by the Federal Communications Commission and the NTIA.

Primary Service. A service that has full rights in a band of frequencies and can claim protection from harmful interference from other services.

Secondary Service. Service that can be obtained on a noninterference operation basis with primary service users. Stations of a secondary service shall not cause harmful interference to stations of a primary service and cannot claim protection from interference from stations of a primary service; however, they can claim protection from harmful interference from other secondary stations to which frequencies were assigned at a later date.

2.3 UHF Bands

The bands used for telemetry are described unofficially as the L band from 1435 to 1535 MHz, the S band from 2200 to 2300 MHz, and the upper S band from 2310 to 2390 MHz. While these band designations are common in telemetry parlance, they may have no specific meaning to anyone else. Telemetry assignments are made for testing² manned and unmanned aircraft, missiles, space vehicles, rocket sleds and systems carried on such sleds, or for testing their major components.

2.3.1 Allocation of the L Band (1435 to 1535 MHz). This band is allocated in the United States of America and its possessions for government and nongovernment aeronautical telemetry use on a shared basis. The nongovernment use of this band is coordinated by the Aerospace and Flight Test Radio Coordinating Council (AFTRCC). The frequencies in this range will be assigned for aeronautical telemetry and associated remote-control operations³ for testing of manned or unmanned aircraft, missiles, rocket sleds, and other vehicles or their major components. Authorized usage includes telemetry associated with launching and reentry into the Earth's atmosphere as well as any incidental orbiting prior to reentry of manned or unmanned vehicles undergoing flight tests. The following frequencies are shared with flight telemetering mobile stations: 1444.5, 1453.5, 1501.5, 1515.5, 1524.5, and 1525.5 MHz.

2.3.1.1 1435 to 1525 MHz. This frequency range is allocated for the exclusive use of aeronautical telemetry in the United States of America.

2.3.1.2 1525 to 1530 MHz. The 1525- to 1530-MHz band was reallocated at the 1992 World Administrative Radio Conference (WARC-92). The Mobile-Satellite Service is now a primary service in this band. The Mobile Service (includes aeronautical telemetry) is now a secondary service in this band.

2.3.1.3 1530 to 1535 MHz. The Maritime Mobile-Satellite Service is a primary service in the frequency band from 1530 to 1535 MHz.⁴ The Mobile Service (including aeronautical telemetry) is a secondary service in this band.

²A telemetry system as defined here is not critical to the operational (tactical) function of the system.

³The word used for remote control operations in this band is *telecommand*.

⁴Reallocated as of 1 January 1990.

2.3.2 Allocation of the S Band (2200 to 2300 MHz). No provision is made in this band for the flight testing of manned aircraft.

2.3.2.1 2200 to 2290 MHz. These frequencies are shared equally by the United States Government's fixed, mobile, space research, space operation and Earth exploration-satellite services. These frequencies include telemetry associated with launch vehicles, missiles, upper atmosphere research rockets, and space vehicles regardless of their trajectories.

2.3.2.2 2290 to 2300 MHz. Allocations in this range are for the space research service (deep space only) on a shared basis with the fixed and mobile (except aeronautical mobile) services.

2.3.3 Allocation of the Upper S Band (2310 to 2390 MHz). This band is allocated to the radiolocation and mobile services in the United States of America. Government and nongovernment telemetry users share this band in a manner similar to that of the L band. Telemetry assignments are made for flight testing of manned or unmanned aircraft, missiles, space vehicles, or their major components. The frequencies 2312.5, 2332.5, 2352.5, 2364.5, 2370.5, and 2382.5 MHz are also designated for use by both government and nongovernment stations on a co-equal basis for telemetering and associated telecommand operations for expendable and reusable launch vehicles whether or not such operations involve flight testing. Such uses will be limited to 1-MHz bandwidths.

2.3.3.1 2310 to 2360 MHz. These frequencies have been reallocated and were auctioned by the Federal Communications Commission in April 1997. The Wireless Communications Service is the primary service in the frequencies 2305-2320 MHz and 2345-2360 MHz. The Digital Audio Radio Satellite Service is the primary service in the 2320-2345 MHz band. In the band 2310-2360 MHz, the mobile and radiolocation services are allocated on a primary basis until 1 January 1997 or until broadcasting-satellite (sound) service has been brought into use in such a manner as to affect or be affected by the mobile and radiolocation services in those service areas, whichever is later. Aeronautical telemetry will become a secondary service when these services start using the band.

2.3.3.2 2360 to 2390 MHz. The Mobile Service (including aeronautical telemetry) is a primary service in this band. The Balanced Budget Act of 1997 resulted in the reallocation of 2385-2390 MHz to other applications. The Mobile Service will no longer be a primary service in this frequency range after 2005 (or 2007 in some areas).

2.4 UHF Telemetry Transmitter Systems

Air- and space-ground telemetry is accommodated in the appropriate UHF bands 1435 to 1535, 2200 to 2300, and 2310 to 2390 MHz as described in paragraph 2.3.

2.4.1 Center Frequency Tolerance. Unless otherwise dictated by a particular application, the frequency tolerance for a telemetry transmitter shall be ± 0.002 percent of the transmitter's assigned center frequency. Transmitter designs shall control transient frequency errors associated with startup and power interruptions. During the first second after turn on, the transmitter output frequency shall be within the occupied bandwidth of the modulated signal at any time when the transmitter output power exceeds -25 dBm. Between 1 and 5 seconds after initial turn on, the transmitter frequency shall remain within twice the specified limits for the assigned radio frequency. After 5 seconds, the standard frequency tolerance is applicable for any and all operations where the transmitter power output is -25 dBm or greater (or produces a field strength greater than 320 $\mu\text{V}/\text{meter}$ at a distance of 30 meters from the transmitting antenna in any direction). Specific uses may dictate tolerances more stringent than those stated.

2.4.2 Channel Bandwidth Definitions. Channel bandwidths are defined below.

2.4.2.1 Standard Bandwidth Signal. A standard bandwidth signal occupies a bandwidth less than or equal to 1 MHz.

2.4.2.2 Wide Bandwidth Signal. A wide bandwidth signal occupies a bandwidth greater than 1 MHz.⁵

2.4.3 Channelization. Channel spacings for all types of telemetry uses are described in the following subparagraphs.

2.4.3.1 Standard Bandwidth Channels. Standard bandwidth channel spacing is in increments of 1 MHz, beginning 500 kHz from the lower band edge, such as 1435.5, 1436.5, and 1437.5 MHz. By definition, the band edges of a standard bandwidth channel cannot fall outside the allocated band.

2.4.3.2 Wide Bandwidth Channels. Channels with bandwidths greater than 1 MHz are assigned channels on spacings as standard bandwidth channels. The resulting spectrum is not allowed to fall outside the allocated band.

⁵Telemetry systems with bandwidths greater than 10 MHz, operating on the standard telemetry bands, are highly discouraged.

2.4.4 Output Power. Emitted power levels shall always be limited to the minimum required for the application. The output power shall not exceed 25 watts⁶. The effective isotropic radiated power (EIRP) shall not exceed 25 watts⁷.

2.4.5 Modulation. The traditional modulation methods for aeronautical telemetry are frequency modulation and phase modulation. Frequency and phase modulation have a variety of desirable features but may not provide the required bandwidth efficiency especially for higher bit rates. When better bandwidth efficiency is required, the standard method for digital signal transmission is Feher's-patented quadrature phase shift keying (FQPSK-B). FQPSK-B is a nearly constant envelope and is compatible with non-linear amplifiers with minimal spectral regrowth and minimal degradation of detection efficiency. Additional FQPSK-B characteristics are discussed in section 7 of Appendix A.

2.4.5.1 Characteristics of FQPSK-B. FQPSK-B is described in Digcom Inc. document, "FQPSK-B, Revision A1, Digcom-Feher Patented Technology Transfer Document, January 15, 1999". This document can be obtained under a license from:

Digcom Inc.
44685 Country Club Drive
El Macero, CA 95618
Telephone: 530-753-0738
FAX: 530-753-1788

2.4.5.1.1 Differential Encoding. Differential encoding shall be provided and shall be consistent with the following definitions:

The NRZ-L data bit sequence $\{b_n\}$ is sampled periodically by the transmitter at time instants

$$t = nT_b \qquad n = 0,1,2,\dots$$

where T_b is the NRZ-L bit period. Using the bit index values n as references to the beginning of symbol periods, the differential encoder alternately assembles I channel and Q channel symbols to form the sequences

$$I_2, I_4, I_6, \dots$$

and

$$Q_3, Q_5, Q_7, \dots$$

⁶An exemption from this power limit will be considered; however, systems with transmitter power levels greater than 25 watts will be considered nonstandard systems and will require additional coordination with affected test ranges.

⁷An exemption from this EIRP limit will be considered; however, systems with EIRP levels greater than 25 watts will be considered nonstandard systems and will require additional coordination with affected test ranges.

according to the following rules:

$$I_{2n} = b_{2n} \oplus \overline{Q}_{(2n-1)} \quad n > 0 \quad (2-1)$$

$$Q_{(2n+1)} = b_{(2n+1)} \oplus I_{2n} \quad n > 0 \quad (2-2)$$

where \oplus denotes the exclusive-or operator, and the bar above a variable indicates the ‘not’ or inversion operator. Q channel symbols are offset (delayed) relative to I channel symbols by one bit period.

2.4.5.1.2 Data Randomization. The data input to the transmitter shall be randomized using either an encryptor that provides randomization or an Interrange Instrumentation Group (IRIG) 15-bit randomizer as described in Chapter 6 and Appendix D. The purpose of the randomizer is to prevent degenerative data patterns from degrading data quality.

2.4.5.1.3 Quadrature Modulator Phase Map. Table 2-1 lists the mapping from the input to the modulator (after differential encoding and FQPSK-B wavelet assembly) to the carrier phase of the modulator output. The amplitudes in table 2-1 are $\pm a$, where “a” is a normalized amplitude.

TABLE 2-1. FQPSK-B PHASE MAP.		
I Channel	Q Channel	Resultant Phase
a	a	45 degrees
-a	a	135 degrees
-a	-a	225 degrees
a	-a	315 degrees

2.4.5.1.4 Bit Rate. The bit rate range for FQPSK-B shall be between 1 Mb/s and 20 Mb/s.

2.4.5.1.5 Transmitter Phase Noise. The sum of all discrete spurious spectral components (single sideband) shall be less than -36 dBc. The continuous single sideband phase noise power spectral density (PSD) shall be below the curve shown in figure 2-1. The maximum frequency for the curve in figure 2-1 is one-fourth of the bit rate. For bit rates greater than 4 Mb/s, the phase noise PSD shall be less than -100 dBc/Hz between 1 MHz

and one-fourth of the bit rate.

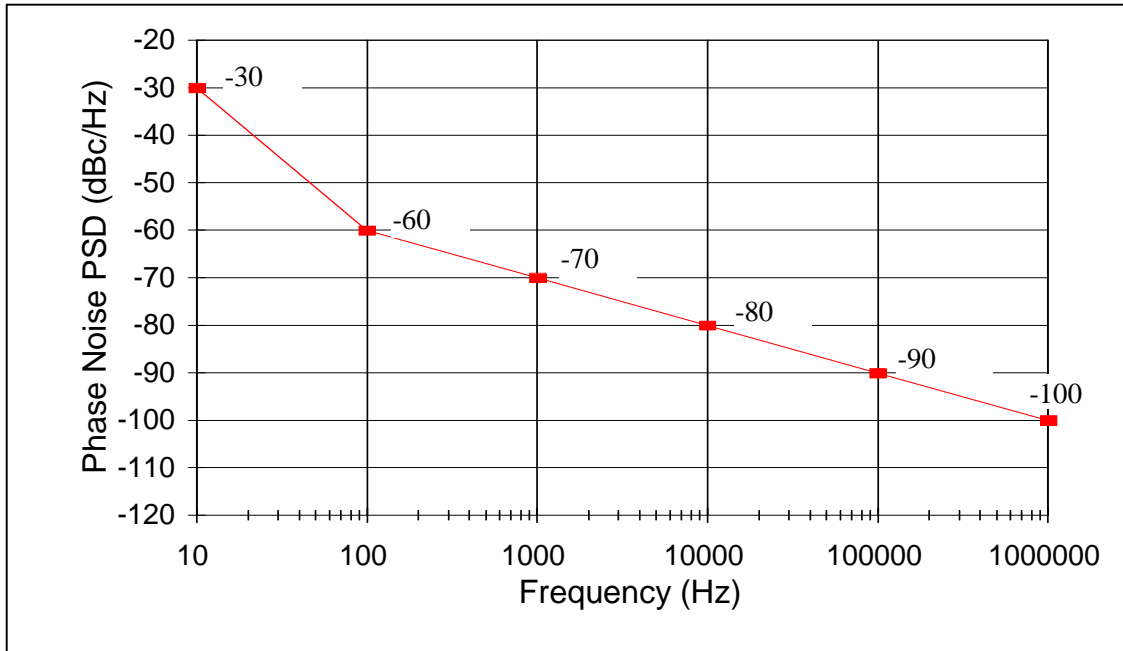

Figure 2-1. Continuous single sideband phase noise power spectral density.

2.4.5.1.6 Carrier Suppression. The remnant carrier level shall be no greater than -25 dBc. Paragraph 7.0 of Appendix A contains additional discussion of carrier suppression.

2.4.5.2 Modulation Polarity. An increasing voltage at the input of a frequency modulation (FM) transmitter shall cause an increase in output carrier frequency. An increase in voltage at the input of a phase modulation (PM) transmitter shall cause an advancement in the phase of the output carrier. An increasing voltage shall cause an increase in the output power of an amplitude modulation (AM) transmitter.

2.4.6 Spurious Emission and Interference Limits. Spurious⁸ emissions from the transmitter case, through input and power leads, and at the transmitter radio frequency (RF) output and antenna-radiated spurious emissions are to be within required limits shown in MIL-STD-461, Electromagnetic Emission and Susceptibility Requirements for the Control of Electromagnetic Interference, when measured by the methods and equipment shown in MIL-STD-462, Electromagnetic Interference Characteristics, Measurement. Other applicable standards and specifications may be used in place of MIL-STD-461 and MIL-STD-462, if necessary.

⁸Any unwanted signal or emission is spurious whether or not it is related to the transmitter frequency (harmonic).

2.4.6.1 Transmitter-Antenna System Emissions. Emissions from the antenna are of primary importance. For example, a tuned antenna may or may not attenuate spurious frequency products produced by the transmitter, and an antenna or multi-transmitter system may generate spurious outputs when a pure signal is fed to its input. The transmitting pattern of such spurious frequencies is generally different from the pattern at the desired frequency. Spurious outputs in the transmitter output line shall be limited to -25 dBm. Antenna-radiated spurious outputs shall be no greater than 320 µV/meter at 30 meters in any direction.



WARNING: Spurious levels of -25 dBm may severely degrade the performance of sensitive receivers whose antennas are located in close proximity to the telemetry transmitting antenna. Therefore, lower spurious levels may be required in certain frequency ranges, such as near GPS L1 and L2 frequencies.

2.4.6.2 Conducted and Radiated Interference. Interference (and the RF output itself) radiated from the transmitter or fed back into the transmitter power, signal, or control leads could interfere with the normal operation of the transmitter or the antenna system to which the transmitter is connected. All signals conducted by the transmitter's leads (other than the RF output cable) in the range of 150 kHz to 50 MHz, and all radiated fields in the range of 150 kHz to 10 GHz (or other frequency ranges as specified) must be within the limits of the applicable standards or specifications.

2.4.7 Operational Flexibility. Each transmitter shall be capable of operating at all frequencies within its allocated band without design modification⁹.

2.4.8 Modulated Transmitter Bandwidth.¹⁰ Telemetry applications covered by this standard shall use 99-percent power bandwidth to define occupied bandwidth and -25 dBm bandwidth as the primary measure of spectral efficiency. The -25 dBm bandwidth is the minimum bandwidth that contains all spectral components that are -25 dBm or larger. A power level of -25 dBm is exactly equivalent to an attenuation of the transmitter power by $55 + 10 \times \log(P)$ dB where P is the transmitter power expressed in watts. The spectra are assumed symmetrical about the transmitter's center frequency unless specified otherwise. All spectral components larger than $-(55 + 10 \times \log(P))$ dBc at the transmitter output must be within the spectral mask calculated using the following equation:

$$M(f) = K + 90 \log R - 100 \log |f - f_c|; \quad |f - f_c| \geq \frac{R}{m} \quad (2-3)$$

where

$M(f)$ = power relative to P (i.e., units of dBc) at frequency f (MHz)

⁹The intent is that fixed frequency transmitters can be used at different frequencies by changing crystals or other components. All applicable performance requirements will be met after component change.

¹⁰These bandwidths are measured using a spectrum analyzer with the following settings: 10-kHz resolution bandwidth, 1-kHz video bandwidth, and max hold detector.

K	= -20 for analog signals
K	= -28 for binary signals
K	= -63 for quaternary signals (e.g., FQPSK-B)
f_c	= transmitter center frequency (MHz)
R	= bit rate (Mb/s) for digital signals or ($\Delta f + f_{\max}$) (MHz) for analog FM signals
m	= number of states in modulating signal; m = 2 for binary signals m = 4 for quaternary signals and analog signals
Δf	= peak deviation
f_{\max}	= maximum modulation frequency

Note that the mask in this standard is different than the mask contained in the 1996 and 1999 versions of the Telemetry Standards, and, in general, narrower. Equation (2-3) does not apply to spectral components separated from the center frequency by less than R/m . The -25 dBm bandwidth is not required to be narrower than 1 MHz. Binary signals include all modulation signals with two states while quaternary signals include all modulation signals with four states (quadrature phase shift keying and FQPSK-B are two examples of four-state signals). Appendix A, paragraph 6.0, contains additional discussion and examples of this spectral mask.

2.5 UHF Telemetry Receiver Systems

As a minimum, UHF receiver systems shall have the following characteristics:

2.5.1 Spurious Emissions. The RF energy radiated from the receiver itself or fed back into the power supply, and/or the RF input, output, and control leads in the range from 150 kHz to 10 GHz shall be within the limits specified in MIL-STD 461. It shall be tested in accordance with MIL-STD 462 or RCC Document 118, volume II, Test Methods for Telemetry RF Subsystems. Other applicable standards and specifications may be used in place of MIL-STD-461 and MIL-STD-462, if necessary.

2.5.2 Frequency Tolerance. The accuracy of all local oscillators within the receiver shall be such that the conversion accuracy at each stage and overall is within ± 0.001 percent of the indicated tuned frequency under all operating conditions for which the receiver is specified.

2.5.3 Receiver Phase Noise. The sum of all discrete spurious spectral components (single sideband) shall be less than -39 dBc. The continuous single sideband phase noise power spectral density (PSD) shall be 3 dB below the curve shown in figure 2-1. The maximum frequency for the curve in figure 2-1 is one-fourth of the bit rate. For bit rates greater than 4 Mb/s, the phase noise PSD shall be less than -103 dBc/Hz between 1 MHz and one-fourth of the bit rate.

2.5.4 Spurious Responses. Rejection of any frequency other than the one to which the receiver is tuned shall be a minimum of 60 dB referenced to the desired signal over the range 150 kHz to 10 GHz.

2.5.5 Operational Flexibility. All ground-based receivers shall be capable of operating over the entire band for which they are designed. External downconverters may be either intended for the entire band or a small portion but capable of retuning anywhere in the band without modification.

2.5.6 Intermediate Frequency Bandwidths. The standard receiver intermediate frequency (IF) bandwidths are shown in table 2-2. These bandwidths are separate from and should not be confused with post-detection low-pass filtering that receivers provide¹¹. The ratio of the receiver's -60 dB bandwidth to the -3 dB bandwidth shall be less than 5.



NOTE For data receivers, the IF bandwidth should typically be selected so that 90 to 99 percent of the transmitted spectrum is within the receiver 3-dB bandwidth. In most cases, the optimum IF bandwidth will be narrower than the 99-percent power bandwidth measured using the method outlined in Appendix A, subparagraph 5.2.1.

TABLE 2-2. STANDARD RECEIVER IF BANDWIDTHS.

300 kHz†	1.5 MHz‡	6 MHz‡
500 kHz†	2.4 MHz‡	10 MHz‡
750 kHz†	3.3 MHz‡	15 MHz‡
1000 kHz†	4.0 MHz‡	20 MHz‡

‡ see note next page

† see note next page

¹¹In most instances, the output low-pass filter should *not* be used to "clean up" the receiver output prior to use with demultiplexing equipment.



1. Bandwidths are expressed at the points where response is 3 dB below the response at the design center frequency, assuming that passband ripple is minimal, which may not necessarily be the case. The 3-dB bandwidth is chosen, because it closely matches the noise bandwidth of a "brick-wall" filter of the same bandwidth. The "optimum" bandwidth for a specific application may be other than that stated here. Ideal IF filter response is symmetrical about its center frequency; in practice, this may not be the case.
2. Not all bandwidths are available on all receivers or at all test ranges. Additional receiver bandwidths may be available at some test ranges.
3. (†) Bandwidths are for use with standard bandwidth channels.
4. (‡) Bandwidths are for use with wide bandwidth channels.

CHAPTER 3

FREQUENCY DIVISION MULTIPLEXING TELEMETRY STANDARDS

3.1 General

In frequency division multiplexing, each data channel makes use of a separate subcarrier which occupies a defined position and bandwidth in the modulation baseband of the RF carrier. Two types of frequency modulation (FM) subcarrier formats may be used. The data bandwidth of one format type is proportional to the subcarrier center frequency, while the data bandwidth of the other type is constant, regardless of subcarrier frequency.

3.2 FM Subcarrier Characteristics

In these systems, one or more subcarrier signals, each at a different frequency, are employed to frequency modulate (FM) or phase modulate (PM) a transmitter in accordance with the RF conditions specified in chapter 2. The following subparagraphs set forth the standards for utilization of FM frequency division multiplexing.

3.2.1 Each of the subcarriers conveys measurement data in FM form. The number of data channels may be increased by modulating one or more of the subcarriers with a time-division multiplex format such as pulse-code modulation (PCM).

3.2.2 The selecting and grouping of subcarrier channels depend upon the data bandwidth requirements of the application at hand and upon the necessity to ensure adequate guard bands between channels. Combinations of both proportional-bandwidth channels and constant-bandwidth channels may be used.

3.3 FM Subcarrier Channel Characteristics

The following subparagraphs describe the characteristics of proportional-bandwidth and constant-bandwidth FM subcarrier channels.

3.3.1 Proportional-Bandwidth FM Subcarrier Channel Characteristics. Table 3-1 lists the standard proportional-bandwidth FM subcarrier channels. The channels identified with letters permit ± 15 or ± 30 percent subcarrier deviation rather than ± 7.5 percent deviation but use the same frequencies as the 12 highest channels. The channels shall be used within the limits of maximum subcarrier deviation. See appendix B for expected performance tradeoffs at selected combinations of deviation and modulating frequency.

TABLE 3-1. PROPORTIONAL-BANDWIDTH FM SUBCARRIER CHANNELS

±7.5% CHANNELS

Channel	Center Frequencies (Hz)	Lower Deviation Limit (Hz)	Upper Deviation Limit (Hz)	Nominal Frequency Response (Hz)	Nominal Rise Time (ms)	Maximum Frequency Response (Hz)	Minimum Rise Time (ms)
1	400	370	430	6	58	30	11.7
2	560	518	602	8	44	42	8.33
3	730	675	785	11	32	55	6.40
4	960	888	1032	14	25	72	4.86
5	1300	1202	1398	20	18	98	3.60
6	1700	1572	1828	25	14	128	2.74
7	2300	2127	2473	35	10	173	2.03
8	3000	2775	3225	45	7.8	225	1.56
9	3900	3607	4193	59	6.0	293	1.20
10	5400	4995	5805	81	4.3	405	.864
11	7350	6799	7901	110	3.2	551	.635
12	10 500	9712	11 288	160	2.2	788	.444
13	14 500	13 412	15 588	220	1.6	1088	.322
14	22 000	20 350	23 650	330	1.1	1650	.212
15	30 000	27 750	32 250	450	.78	2250	.156
16	40 000	37 000	43 000	600	.58	3000	.117
17	52 500	48 562	56 438	788	.44	3938	.089
18	70 000	64 750	75 250	1050	.33	5250	.06
19	93 000	86 025	99 975	1395	.25	6975	.050
20	124 000	114 700	133 300	1860	.19	9300	.038
21	165 000	152 625	177 375	2475	.14	12 375	.029
22	225 000	208 125	241 875	3375	.10	16 875	.021
23	300 000	277 500	322 500	4500	.08	22 500	.016
24	400 000	370 000	430 000	6000	.06	30 000	.012
25	560 000	518 000	602 000	8400	.04	42 000	.008

See notes at end of table.

TABLE 3-1 (CONT'D). PROPORTIONAL-BANDWIDTH FM SUBCARRIER CHANNELS

±15% CHANNELS

Channel	Center Frequencies (Hz)	Lower Deviation Limit (Hz)	Upper Deviation Limit (Hz)	Nominal Frequency Response (Hz)	Nominal Rise Time (ms)	Maximum Frequency Response (Hz)	Minimum Rise Time (ms)
A	22 000	18 700	25 300	660	.53	3300	.106
B	30 000	25 500	34 500	900	.39	4500	.078
C	40 000	34 000	46 000	1200	.29	6000	.058
D	52 500	44 625	60 375	1575	.22	7875	.044
E	70 000	59 500	80 500	2100	.17	10 500	.033
F	93 000	79 050	106 950	2790	.13	13 950	.025
G	124 000	105 400	142 600	3720	.09	18 600	.018
H	165 000	140 250	189 750	4950	.07	24 750	.014
I	225 000	191 250	258 750	6750	.05	33 750	.010
J	300 000	255 000	345 000	9000	.04	45 000	.008
K	400 000	340 000	460 000	12 000	.03	60 000	.006
L	560 000	476 000	644 000	16 800	.02	84 000	.004

See notes at end of table.

TABLE 3-1 (CONT'D). PROPORTIONAL-BANDWIDTH FM SUBCARRIER CHANNELS**±30% CHANNELS**

Channel	Center Frequencies (Hz)	Lower Deviation Limit (Hz)	Upper Deviation Limit (Hz)	Nominal Frequency Response (Hz)	Nominal Rise Time (ms)	Maximum Frequency Response (Hz)	Minimum Rise Time (ms)
AA	22 000	15 400	28 600	1320	.265	6600	.053
BB	30 000	21 000	39 000	1800	.194	9000	.038
CC	40 000	28 000	52 000	2400	.146	12 000	.029
DD	52 500	36 750	68 250	3150	.111	15 750	.022
EE	70 000	49 000	91 000	4200	.083	21 000	.016
FF	93 000	65 100	120 900	5580	.063	27 900	.012
GG	124 000	86 800	161 200	7440	.047	37 200	.009
HH	165 000	115 500	214 500	9900	.035	49 500	.007
II	225 000	157 500	292 500	13 500	.026	67 500	.005
JJ	300 000	210 000	390 000	18 000	.019	90 000	.004
KK	400 000	280 000	520 000	24 000	.015	120 000	.003
LL	560 000	392 000	728 000	33 600	.010	168 000	.002

Round off to nearest Hz.

The indicated maximum data frequency response and minimum rise time is based on the maximum theoretical response that can be obtained in a bandwidth between the upper and lower frequency limits specified for the channels. See appendix B, paragraph 3.0 for determining possible accuracy versus response tradeoffs.

Channels A through L may be used by omitting adjacent lettered and numbered channels. Channels 13 and A may be used together with some increase in adjacent channel interference.

Channels AA through LL may be used by omitting every four adjacent double lettered and lettered channels and every three adjacent numbered channels. Channels AA through LL may be used by omitting every three adjacent double lettered and lettered channels and every two adjacent numbered channels with some increase in adjacent channel interference.

3.3.2 Constant-Bandwidth FM Subcarrier Channel Characteristics.

Table 3-2 lists the standard constant-bandwidth FM subcarrier channels. The letters A, B, C, D, E, F, G, and H identify the channels for use with maximum subcarrier deviations of ± 2 , ± 4 , ± 8 , ± 16 , ± 32 , ± 64 , ± 128 , and ± 256 kHz, along with maximum frequency responses of 2, 4, 8, 16, 32, 64, 128, and 256 kHz. The channels shall be used within the limits of maximum subcarrier deviation. See appendix B for expected performance tradeoffs at selected combinations of deviation and modulating frequencies.

3.4 Tape Speed Control and Flutter Compensation

Tape speed control and flutter compensation for FM/FM formats may be accomplished as indicated in subparagraph 6.8.4, chapter 6. The standard reference frequency used shall be in accordance with the criteria in table 3-3 when the reference signal is mixed with data.

TABLE 3-2. CONSTANT-BANDWIDTH FM SUBCARRIER CHANNELS.

<u>A CHANNELS</u>	<u>B CHANNELS</u>	<u>C CHANNELS</u>	<u>D CHANNELS</u>	<u>E CHANNELS</u>	<u>F CHANNELS</u>	<u>G CHANNELS</u>	<u>H CHANNELS</u>
Deviation limits = ± 2 kHz	Deviation limits = ± 4 kHz	Deviation limits = ± 8 kHz	Deviation limits = ± 16 kHz	Deviation limits = ± 32 kHz	Deviation limits = ± 64 kHz	Deviation limits = ± 128 kHz	Deviation limits = ± 256 kHz
Nominal frequency response = 0.4 kHz	Nominal frequency response = 0.8 kHz	Nominal frequency response = 1.6 kHz	Nominal frequency response = 3.2 kHz	Nominal frequency response = 6.4 kHz	Nominal frequency response = 12.8 kHz	Nominal frequency response = 25.6 kHz	Nominal frequency response = 51.2 kHz
Maximum frequency response = 2 kHz	Maximum frequency response = 4 kHz	Maximum frequency response = 8 kHz	Maximum frequency response = 16 kHz	Maximum frequency response = 32 kHz	Maximum frequency response = 64 kHz	Maximum frequency response = 128 kHz	Maximum frequency response = 256 kHz
Center Frequency (kHz)	Center Frequency (kHz)	Center Frequency (kHz)	Center Frequency (kHz)	Center Frequency (kHz)	Center Frequency (kHz)	Center Frequency (kHz)	Center Frequency (kHz)
8	16	32	64	128	256	512	1024
16	32	64	128	256	512	1024	2048
24	48	96	192	384	768	1536	3072
32	64	128	256	512	1024	2048	
40	80	160	320	640	1280	2560	
48	96	192	384	768	1536	3072	
56	112	224	448	896	1792	3584	
64	128	256	512	1024	2048		
72	144	288	576	1152	2304		
80	160	320	640	1280	2560		
88	176	352	704	1408	2816		
96	192	384	768	1536	3072		
104	208	416	832	1664	3328		
112	224	448	896	1792	3584		
120	240	480	960	1920	3840		
128	256	512	1024	2048			
136	272	544	1088	2176			
144	288	576	1152	2304			
152	304	608	1216	2432			
160	320	640	1280	2560			
168	336	672	1344	2688			
176	352	704	1408	2816			

The constant-bandwidth channel designation shall be the channel center frequency in kilohertz and the channel letter indicating deviation limit; for example, 16A, indicating $f_c = 16$ kHz, deviation limit of ± 2 kHz.

The indicated maximum frequency is based upon the maximum theoretical response that can be obtained in a bandwidth between deviation limits specified for the channel. See discussion in appendix B for determining practical accuracy versus frequency response trade offs.

Prior to using a channel outside the enclosed area, the user should verify the availability of range assets to support the demodulation of the channel selected. Very limited support is available above 2 MHz.

3-6

TABLE 3-3. REFERENCE SIGNAL USAGE

Reference Frequencies for Tape Speed and Flutter Compensation
Reference Frequency (kHz $\pm 0.01\%$)
960 ¹
480 ¹
240 ¹
200
100
50
25
12.5
6.25
3.125

If the reference signal is recorded on a separate tape track, any of the listed reference frequencies may be used provided the requirements for compensation rate of change are satisfied.

If the reference signal is mixed with the data signal, consideration must be given to possible problems with intermodulation sum and difference frequencies. Also, sufficient guard band must be allowed between the reference frequency and any adjacent data subcarrier.

¹These frequencies are for flutter compensation only and not for capstan servo speed control. In addition, the 240 kHz reference signal may be used as a detranslation frequency in a constant-bandwidth format.

CHAPTER 4

PULSE CODE MODULATION STANDARDS

4.1 General

Pulse code modulation (PCM) data are transmitted as a serial bit stream of binary-coded time-division multiplexed words. When PCM is transmitted, premodulation filtering shall be used to confine the radiated RF spectrum in accordance with appendix A. These standards define pulse train structure and system design characteristics for the implementation of PCM telemetry formats. Additional information and recommendations are provided in appendix C and in RCC document 119, Telemetry Applications Handbook.

4.2 Class Distinctions and Bit-Oriented Characteristics

The PCM formats are divided into two classes for reference. Serial bit stream characteristics are described below prior to frame and word oriented definitions.

4.2.1 Class I and Class II Distinctions. Two classes of PCM formats are covered in this chapter: the basic, simpler types are class I, and the more complex applications are class II. The use of any class II technique requires concurrence of the range involved. All formats with characteristics described in these standards are class I except those identified as class II. The following are examples of class II characteristics:

- bit rates greater than 5 megabits per second (see subparagraph 4.2.2.3)
- word lengths in excess of 16 bits (subparagraph 4.3.1.1)
- fragmented words (subparagraph 4.3.1.2)
- more than 8192 bits or 1024 words per minor frame (subparagraph 4.3.2.1.1)
- unevenly spaced supercommutation (subparagraph 4.3.2.4)
- format changes (paragraph 4.4)
- asynchronous embedded formats (paragraph 4.5)
- tagged data formats (paragraph 4.6)
- formats with data content other than unsigned straight binary, discretized, or complement arithmetic representation for negative numbers such as floating point variables, binary-coded decimal, and gain-and-value.
- asynchronous data transmission (paragraph 4.8)
- merger of multiple format types (such as chapter 8)



The use of fixed frame formats has been a common practice but does not fit all requirements. A verification of range capabilities should be made prior to incorporation of class II features into a telemetry system.

4.2.2 Bit-Oriented Definitions and Requirements. Definitions and requirements relating to serial PCM bit streams are described next.

4.2.2.1 Binary Bit Representation. The following code conventions for representing serial binary ones and zeros are the only permissible representations:

NRZ-L	Bi ϕ -L
NRZ-M	Bi ϕ -M
NRZ-S	Bi ϕ -S

Graphic and written descriptions of these conventions are shown in figure 4-1. Only one convention shall be used within a single PCM bit stream. If Randomized NRZ-L (RNRZ-L) is transmitted, it shall use the 15-bit regeneration pattern as described in chapter 6 and appendix D.

4.2.2.2 Serial Bit Stream Transitions. The transmitted or recorded bit stream shall be continuous and shall contain sufficient transitions to ensure bit acquisition and continued bit synchronization, taking into account the binary representation chosen. (See recommendation in paragraph 1.3, appendix C.)

4.2.2.3 Bit Rate. The RF and recording limits, defined in chapters 2 and 6, should be considered when determining maximum bit rates. The minimum bit rate shall be 10 bps. Bit rates greater than 5 Mbps are class II.

4.2.2.4 Bit Rate Accuracy and Stability. During any period of desired data, the bit rate shall not differ from the specified nominal bit rate by more than 0.1 percent of the nominal rate.

4.2.2.5 Bit Jitter. The bit jitter shall not exceed ± 0.1 of a bit interval referenced to the expected transition time with no jitter. The expected transition time shall be based on the measured average bit period as determined during the immediately preceding 1000 bits.

4.3 Fixed Formats

Characteristics of fixed formats are described below. Fixed formats do not have changes during transmission with regard to frame structure, word length or location, commutation sequence, sample interval, or measurement list.

4.3.1 Word-Oriented Definitions and Requirements. The following definitions and requirements are addressed to word characteristics.

4.3.1.1 Word Length (Class I and II). Individual words may vary in length from 4 bits to not more than 16 bits in class I and not more than 64 bits in class II.



Code Designation	Logic Waveform Levels	Code Waveforms	Code Definitions
NRZ-L	1 0		<u>Non Return to Zero - Level</u> ① “ONE” is represented by one level ② “ZERO” is represented by the other level
NRZ-M	1 0		<u>Non Return to Zero - Mark</u> ① “ONE” is represented by a change in level ② “ZERO” is represented by <u>NO</u> change in level
NRZ-S	1 0		<u>Non Return to Zero - Space</u> ① “ONE” is represented by <u>NO</u> change in level ② “ZERO” is represented by a change in level
Biφ-L	1 0		<u>Bi-Phase - Level</u> ⁽¹⁾ ① “ONE” is represented by a “ONE” level with transition to the “ZERO” level ② “ZERO” is represented by a “ZERO” level with transition to the “ONE” level
Biφ-M ⁽²⁾	1 0		<u>Bi-Phase - Mark</u> ⁽¹⁾ ① “ONE” is represented by <u>NO</u> level change at the beginning of the bit period ② “ZERO” is represented by a level change at the beginning of the bit period
Biφ-S ⁽²⁾	1 0		<u>Bi-Phase - Space</u> ⁽¹⁾ ① “ONE” is represented by a level change at the beginning of the bit period ② “ZERO” is represented by a <u>NO</u> level change at the beginning of the bit period

Figure 4-1. PCM code definitions.

(1) The Biφ codes may be derived from the corresponding NRZ codes by inverting the level for the last half of each bit interval.

(2) The definitions of the mark and space versions of the bi-phase code have been reversed in various editions of the IRIG Telemetry Standards. The Telemetry Group included both definitions in the 1986 and 1993 versions of the Telemetry Standards. In 106-96, the Telemetry Group replaced the 106-93 Biφ-M and Biφ-S definitions with the 106-93 DBiφ-S and DBiφ-M definitions. The 106-93 Biφ-M and DBiφ-S definitions were identical except for a possible inversion and a time delay of one-half bit period. The Biφ-S and DBiφ-M codes were identical with the same exceptions. The inversions do not change the data content, because the information is in the level changes (transitions) not the levels. The differential terminology and code designation have been dropped.

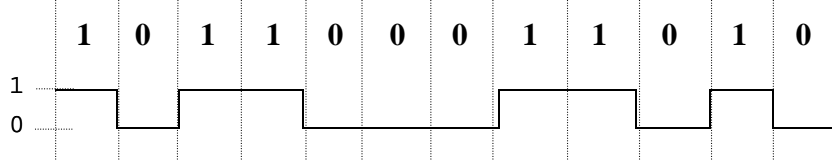
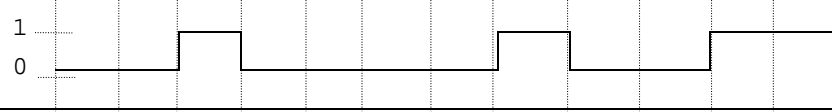
4.3.1.2 Fragmented Words (Class II). A fragmented word is defined as a word divided into no more than eight segments and placed in various locations within a minor frame. The locations need not be adjacent. All word segments used to form a data word are constrained to the boundaries of a single minor frame. Fragmented synchronization words are not allowed.

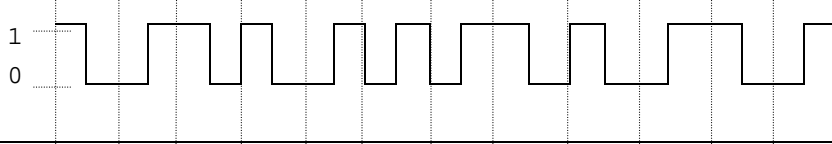
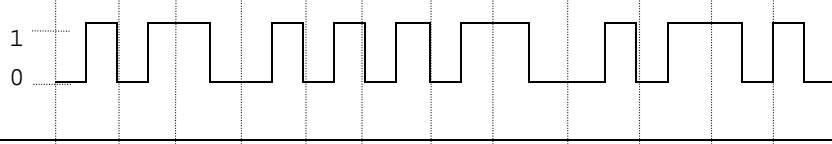
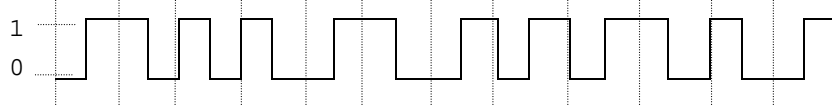
4.3.1.3 Bit Numbering. To provide consistent notation, the most significant bit in a word shall be numbered "one." Less significant bits shall be numbered sequentially within the word.

4.3.1.4 Word Numbering. To provide consistent notation, the first word after the minor frame synchronization pattern shall be numbered "one" (see figure 4-2). Each subsequent word shall be numbered sequentially within the minor frame. Numbering within a subframe (see subparagraph 4.3.2.3.1) shall be "one" for the word in the same minor frame as the initial counter value for subframe synchronization and sequentially thereafter. Notations of W and S shall mean the W word position in the minor frame and S word position in the subframe.

4.3.2 Frame Structure. The PCM data shall be formatted into fixed length frames as defined in these sections regarding frame structure and in figure 4-2. Frames shall contain a fixed number of equal duration bit intervals.

4.3.2.1 Minor Frame. The minor frame is defined as the data structure in time sequence from the beginning of a minor frame synchronization pattern to the beginning of the next minor frame synchronization pattern.

4.3.2.1.1 Minor Frame Length (Class I and II). The minor frame length is the number of bit intervals from the beginning of the frame synchronization pattern to the beginning of the next synchronization pattern. The maximum length of a minor frame shall neither exceed 8192 bits nor 1024 words in class I and shall not exceed 16 384 bits in class II.

4.3.2.1.2 Minor Frame Composition. The minor frame shall contain the minor frame synchronization pattern, data words, and subframe synchronization words, if used. Words of different length may be multiplexed in a single minor frame. The length of a word in any identified word position within a minor frame shall be constant. Other words such as frame format identifiers may be needed within class II formats (see paragraph 4.4).

4.3.2.1.3 Minor Frame Synchronization. The minor frame synchronization information shall consist of a fixed digital word not longer than 33 consecutive bits and not shorter than 16 bits. Recommended synchronization patterns are given in table C-1, appendix C.

4.3.2.1.4 Transmitted Frame Counter. The frame counter provides a natural binary count corresponding to the minor frame number in which the frame count word appears. It is recommended that such a counter be included in all minor frames whether class I or class II and is especially desirable in class II formats to assist with data processing. The

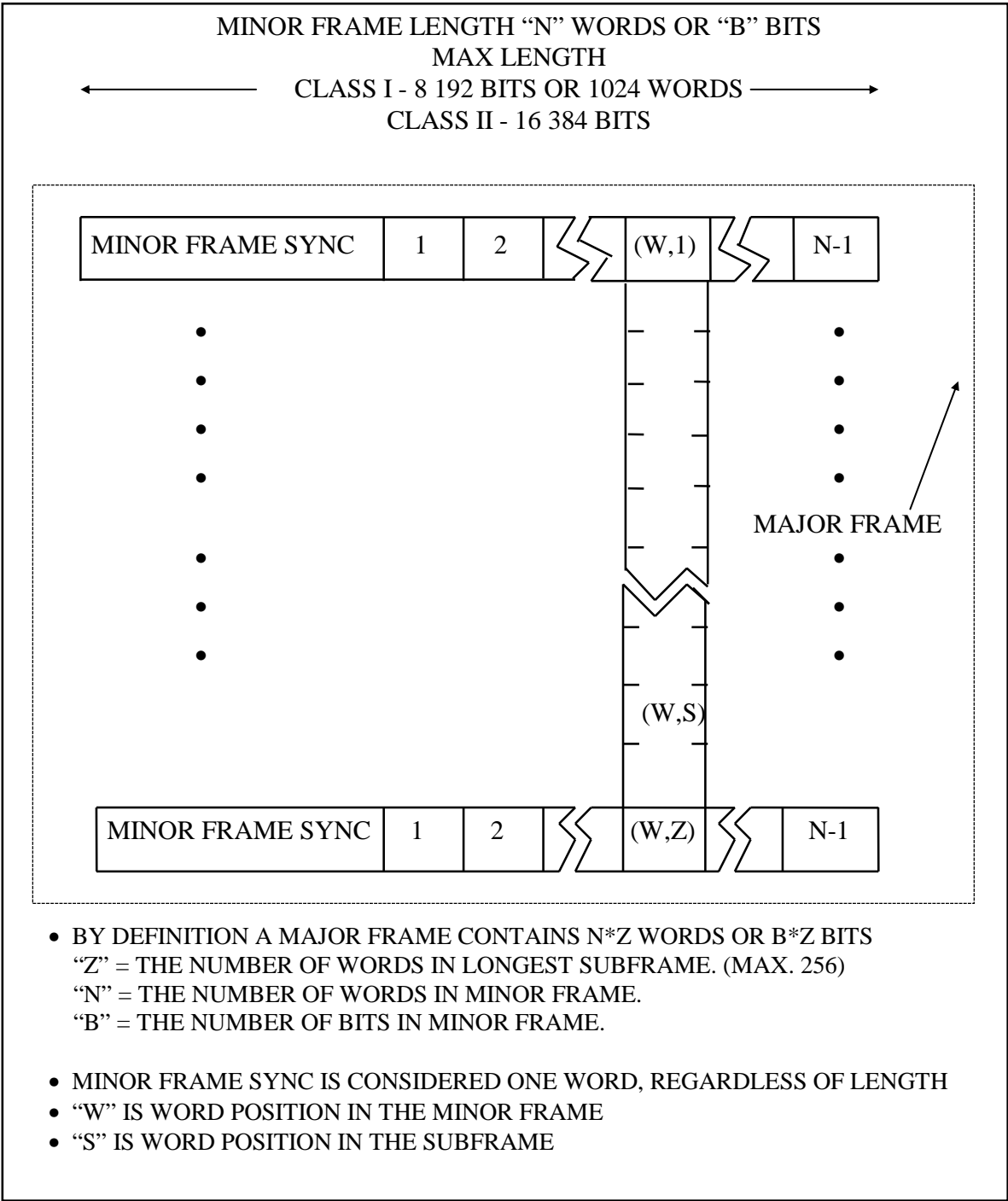

Figure 4-2. PCM frame structure.

frame counter should be of nominal format word length and reset to start upcounting again after reaching maximum value. In formats where subcommutation is present, the subframe ID counter may serve as the frame counter.

4.3.2.2 Major Frame. A major frame contains the number of minor frames required to include one sample of every parameter in the format.

4.3.2.2.1 Major Frame Length. Major frame length is defined as minor frame length (N words or B bits) multiplied by the number of minor frames (Z) in the major frame. The maximum number of minor frames per major frame shall not exceed 256.

4.3.2.2.2 Minor Frame Numbering. To provide consistent notation, the first minor frame in a major frame shall be numbered "one." Each subsequent minor frame shall be numbered sequentially within the major frame.

4.3.2.3 Subcommutation. Subcommutation is defined as a sampling of parameters at submultiple rates (1/D) of the minor frame rate where the depth of a subframe, D, is an integer in the range of 2 to Z.

4.3.2.3.1 Subframe. Subframe is defined as one cycle of the parameters from a subcommutated minor frame word position. The depth, D, of a subframe is the number of minor frames in one cycle before repetition.

4.3.2.3.2 Subframe Synchronization Method. The standard method for subframe synchronization is to use a "subframe ID counter," a binary counter which counts sequentially up or down at the minor frame rate. The counter shall be located in a fixed position in each and every minor frame. A subframe ID counter should start with the minimum counter value when counting up or the maximum counter value when counting down. The counter should also be left or right justified in a word position. The start of a major frame shall coincide with the initial count for the deepest subframe.

4.3.2.4 Supercommutation. Supercommutation ("supercom") is defined as time-division-multiplex sampling at a rate which is a multiple of the minor frame rate. Supercommutation (on a minor frame) provides multiple samples of the same parameter in each minor frame. "Supercom on a subframe" is defined as time-division-multiplex sampling at a rate which is a multiple of the subframe rate and provides multiple samples of the same parameter within a subframe. For class I, supercommutated samples shall be evenly spaced. For class II, supercommutated samples should be as evenly spaced as practical.

4.4 Format Change (Class II)

Format change is defined as change with regard to frame structure, word length or location, commutation sequence, sample interval, or change in measurement list. Format changes shall occur only on minor frame boundaries. Bit synchronization shall be maintained and fill bits used instead of intentional dead periods. Format changes are inherently disruptive to test data processing; fixed format methods are preferred. Format change methods shall conform to the characteristics described in the following sections.

4.4.1 Frame Format Identification. A frame format identifier (FFI) is a word that shall uniquely identify a single format. In formats where change is required, the frame format identifier shall be placed in every minor frame. The format identifier shall be the same length (or multiples of) as the most common word length in the format and shall occur in a fixed position in the minor frame. The FFI shall identify the format applicable to the current minor frame. Frame synchronization pattern, FFI location, bit rate, and binary bit representation code shall not be changed. The FFI shall be constructed such that a single bit error cannot produce another valid FFI. The number of unique formats indicated shall not exceed 16.

4.4.2 Format Change Implementation Methods. The following subparagraphs describe format change implementation methods.

4.4.2.1 Measurement List Change. This method of format change consists of a modification in data content only and not format structure.

4.4.2.2 Format Structure Change. Defined as a format change where there is a departure in frame structure and not just data content.

4.5 Asynchronous Embedded Format (Class II)

Defined as a secondary data stream asynchronously embedded into a host major frame in a manner which does not allow predicting the location of embedded synchronization information based only on host format timing. The embedded frame segments shall be inserted as an integral number of words in every host minor frame. In this combined format, specific word positions in the host minor frame shall be dedicated to the embedded asynchronous format. No more than two asynchronous embedded formats are permitted.

4.6 Tagged Data Format (Class II)

Defined as a fixed frame length format having no applicable subframe or major frame definitions and characterized as a stream of data words, or blocks of words, with associated identifiers (tags). These formats consist of frame synchronization patterns, identifiers, data words, and fill words as required.

4.6.1 Alternating Tag and Data. This tagged data format consists of frames containing tag words alternating in time sequence with data words or blocks of words identified by the tags.

4.6.2 Bus Data Military Standard (MIL-STD) 1553.¹ Telemetry of MIL-STD 1553 information is preferred to be restructured to conform to class I methods. If not, telemetered MIL-STD 1553 data shall conform to chapter 8, paragraph 8.6.

¹Defined in USAF Systems Command MIL-STD 1553, Multiplex Applications Handbook.

4.7 Time Words

The following paragraphs describe the formatting of time words within a PCM stream. A 16-bit standardized time word format and a method to insert time words into PCM word sizes other than 16-bits are described.

4.7.1 In 16-bit standardized time word format, there shall be three words dedicated to providing timing information. These words are designated high order time, low order time, and microsecond time. High and low order time words shall be binary or binary coded decimal (BCD) weighted, and microsecond words shall be binary weighted. Time word construction examples are shown in figure 4-3 and figure 4-4.

4.7.2 The microsecond time word shall have a resolution of 1 microsecond; that is, the least significant bit, bit 16, has a value of 0.000001 second. This word shall increment until it attains a value of 10 milliseconds at which time it will reset to zero. Thus the maximum value of the counter is 9999 (decimal).

4.7.3 The low order time word shall have a resolution of 10 milliseconds; that is, the least significant bit, bit 16, of the low order time word shall have a value of 0.010 second.

4.7.4 The high order time word shall have a resolution of 655.36 seconds when binary weighted; that is, the least significant bit, bit 16, has a value of 655.36 seconds. When BCD weighted, the least significant bit, bit 16, of the high order time word shall have a value of 1 minute. For BCD, the days field shall contain the three least significant characters of the BCD Julian Date.

4.7.5 It is recommended that high, low, and microsecond time words proceed the first data word in the minor frame. The time word order shall be high order time word, followed by low order time word, followed by microsecond time word. Microsecond time words may be used to tag individual data words, but care shall be taken that high order and low order time words be inserted at a rate necessary to resolve time ambiguities.

4.7.6 Time word insertion into PCM word sizes other than 16 bits shall be as follows: high order, low order, and microsecond time words shall be inserted into PCM words with time word bits occupying contiguous bit locations in the PCM word. The time word shall occupy contiguous PCM data words until the time word is contained in the PCM stream. If the time word size is not an integer multiple of the PCM word size and there are unused bits in the PCM word, the remaining unused bits in the last PCM word that contains the time word shall be fill bits with value 0. Figure 4.4 illustrates the insertion of time words into a PCM stream with word size of 12 bits.

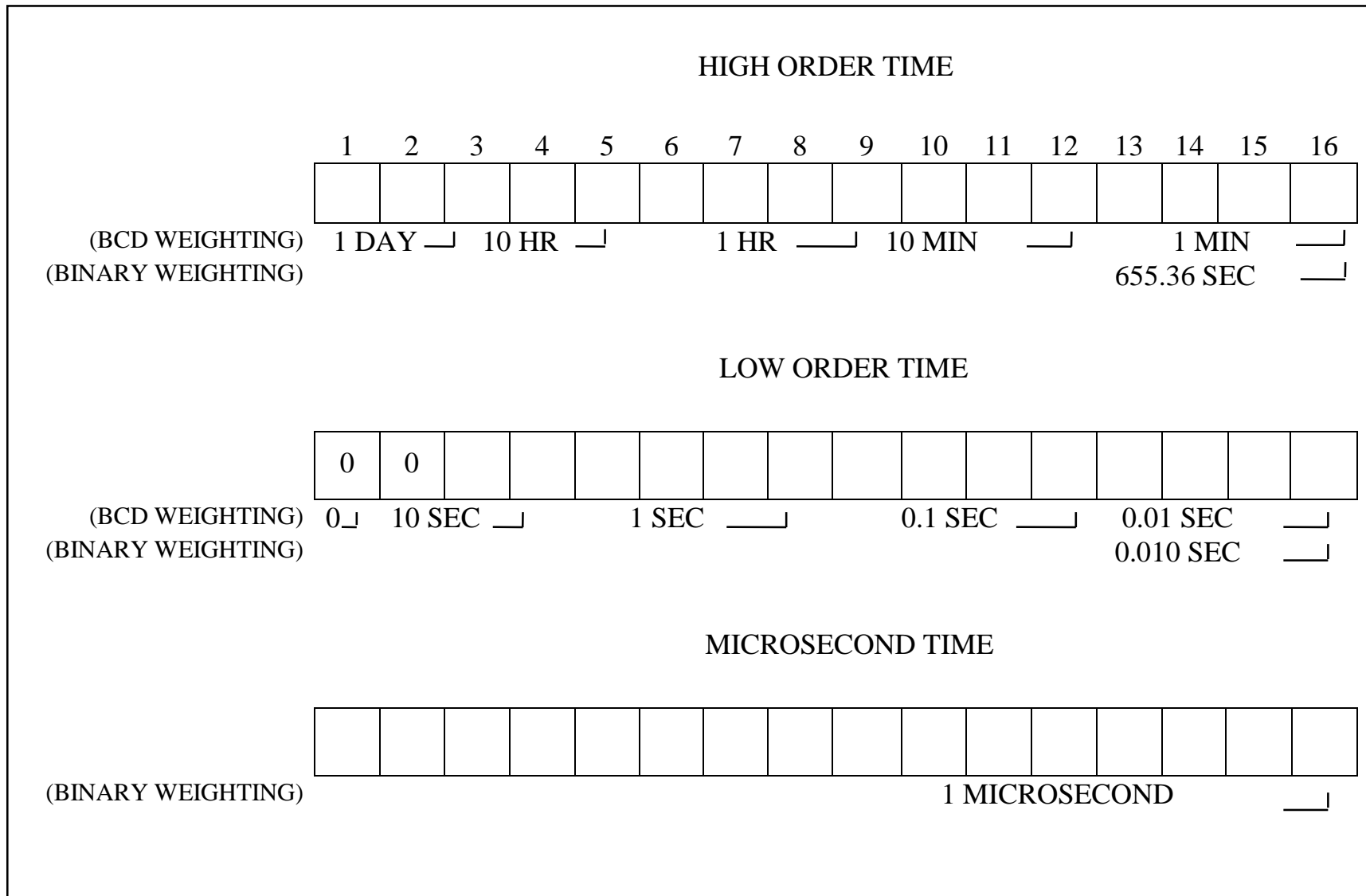

Figure 4-3. 16 bit standardized time word format.

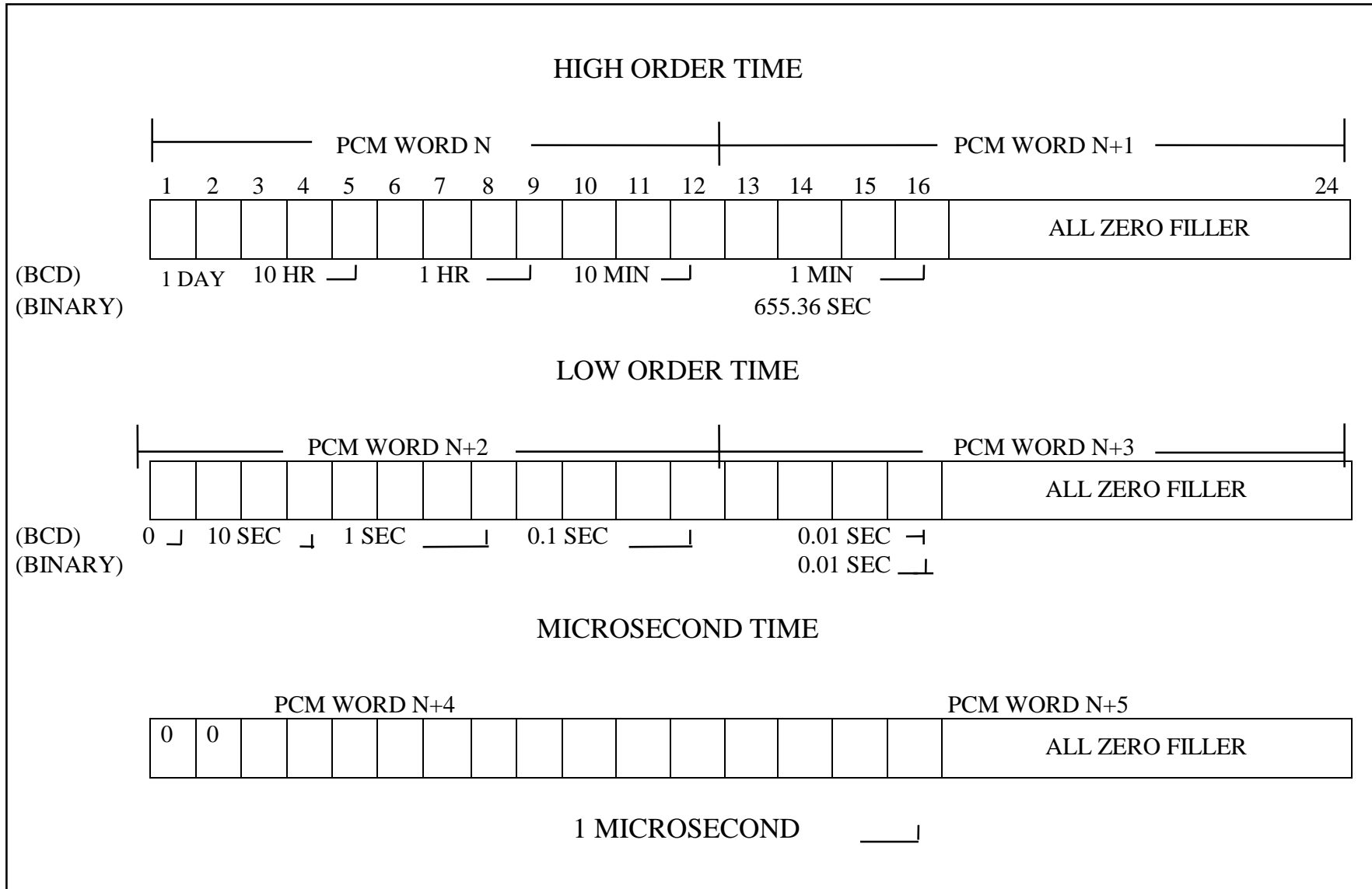

Figure 4-4. Time word insertion into 12 bit PCM word size.

4.7.6 Time word insertion into PCM word sizes other than 16 bits shall be as follows: high order, low order, and microsecond time words shall be inserted into PCM words with time word bits occupying contiguous bit locations in the PCM word. The time word shall occupy contiguous PCM data words until the time word is contained in the PCM stream. If the time word size is not an integer multiple of the PCM word size and there are unused bits in the PCM word, the remaining unused bits in the last PCM word that contains the time word shall be fill bits with value 0. Figure 4.4 illustrates the insertion of time words into a PCM stream with word size of 12 bits.

4.8 Asynchronous Data Merge

Asynchronous data is defined as an external sequential data stream (consisting of data bits, associated overhead, and optional parity, all at an autonomous update rate) which is a candidate for insertion into a primary or “host” PCM format. Common examples are RS-232 serial and IEEE-488 parallel messages. Each source of such data shall use fixed word positions in the host format. This section does not apply to secondary PCM formats which are to be embedded as described in paragraph 4.5. Merger shall comply with subparagraph 4.2.2 and the following conventions.

4.8.1 PCM Data Word Format. Figure 4-5 illustrates the host PCM format word containing a merged asynchronous data word and associated overhead which is referred to as an “asynchronous word structure.” The data may be inserted in any length PCM word that will accommodate the required bits. Asynchronous data shall not be placed in fragmented words. Multiple host PCM format words, if used, shall be contiguous.

4.8.2 Insertion Process. The asynchronous word structure shall contain the information from the asynchronous message partitioned into two fields, data and overhead, as shown in figure 4-5. The asynchronous message is inserted into the asynchronous word structure with the following bit orientations. The most significant data bit (MSB) through least significant data bit (LSB) and parity (if used) of the message are denoted as D1 (MSB) through Di and will be inserted into structure bits B1 (MSB) through Bi. The next two structure bits, B(i+1) and B(i+2) are reserved for the stale and overflow flags generated by the host encoder. All remaining overhead (message and host encoder generated) D(i+3) through Dn (LSB), will be inserted into structure bits B(i+3) through Bn (LSB).

4.8.2.1 Transmission Overhead. All transmission overhead not required for data reconstruction shall be removed.

4.8.2.2 Parity Bit. Transmission of a parity bit is optional. If it is transmitted, it shall be at the end of the data field (see figure 4-5) adjacent to the LSB of the data.

4.8.2.3 Data Bits. The data bits shall be inserted into the PCM word with the most significant bit of the asynchronous data aligned with the most significant bit of the PCM word.

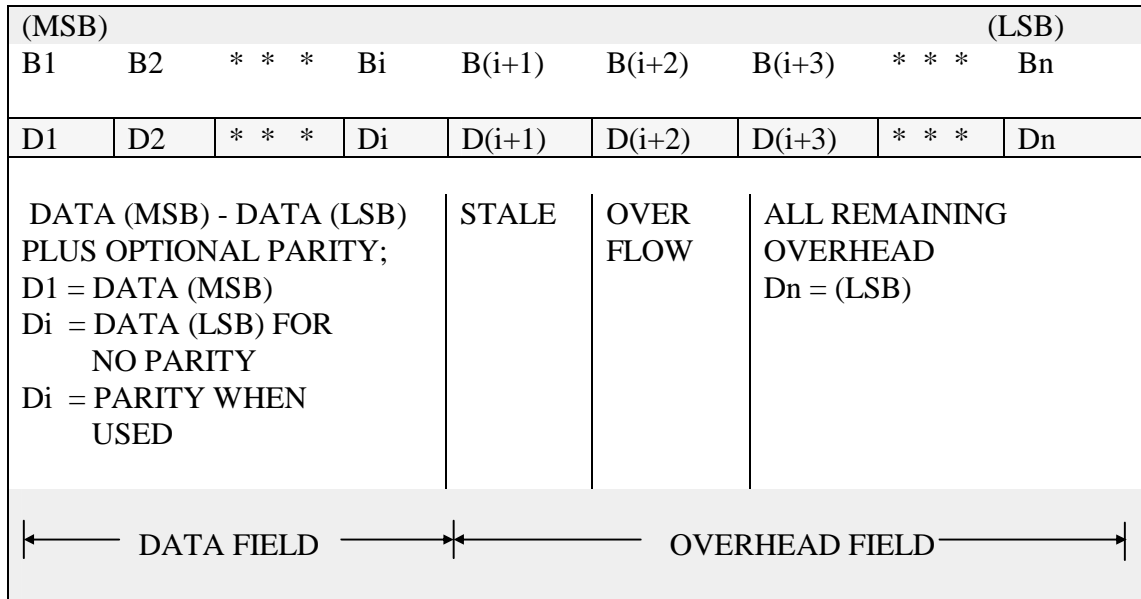

Figure 4-5. Asynchronous word structure.

4.8.2.4 Stale Data Bit. A “stale data bit” flag shall be generated each time a new data value is inserted into the PCM stream. The flag shall be transmitted with the associated data. The flag bit shall be placed in the next less significant bit location following the LSB of the data. If new data is not ready for transmission by the time the PCM word must be sent again, either the old data or alternating one/zero fill shall be sent and the flag set. Stale data shall be indicated by a binary “one” (see figure 4-6).

STALE BIT	OVERFLOW BIT	
0	0	FRESH DATA
0	1	DATA OVERFLOW
1	0	STALE DATA
1	1	USER DEFINED

Figure 4-6. Overhead truth table.

4.8.2.5 Overflow Bit. An “overflow bit” flag shall be generated to indicate an abnormal condition in which data may be lost. The overflow bit shall be placed in the next less significant data bit location following the stale bit flag. An overflow bit at a binary “one” indicates that a data discontinuity exists between the current data word and the previous data word (see figure 4-6).

4.8.2.6 Insertion Rate. The asynchronous word structure shall be inserted into the host PCM word at a rate to avoid data loss in the PCM stream.

CHAPTER 5

DIGITIZED AUDIO TELEMETRY STANDARD

5.1 General

This chapter defines Continuous Variable Slope Delta (CVSD) modulation as the standard for digitizing audio and addresses the method of inserting CVSD encoded audio into a PCM stream. Additional information and recommendations are provided in appendix F, Continuous Variable Slope Delta Modulation. Appendix F was extracted from the applicable sections of MIL-STD-188-113.

5.2 Definitions

For the purpose of this standard, the following definitions apply.

5.2.1 Band-Limited Audio. An audio signal (typically consisting of voice, tones, and sounds) that is limited to a subset of the audio spectrum. For most aircraft audio applications, the spectrum between 100 and 2300 hertz is adequate.

5.2.2 Continuous Variable Slope Delta Modulation. The CVSD modulation is a method of digitizing a band-limited audio signal. The CVSD modulator is, in essence, a 1-bit analog-to-digital converter. The output of this 1-bit encoder is a serial bit stream, where each bit represents an incremental increase or decrease in signal amplitude and is determined as a function of recent sample history.

5.3 Signal Source

The signal to be encoded shall be a band-limited audio signal. The source of this signal may be varied. Some examples are microphones, communication systems, and tones from warning systems. This standard applies to audio signals only.

5.4 Encoding/Decoding Technique

The technique to encode and decode the band-limited audio signal is Continuous Variable Slope Delta (CVSD) modulation. This technique is to be implemented in accordance with appendix F.

A CVSD converter consists of an encoder-decoder pair. The decoder is connected in a feedback path. The encoder receives a band-limited audio signal and compares it to the analog output of the decoder. The result of the comparison is a serial string of "ones" and "zeros." Each bit indicates that the band-limited audio sample's amplitude is above or below the decoded signal. When a run of three identical bits is encountered, the slope of the generated analog approximation is increased in its respective direction

until the identical string of bits is broken. The CVSD decoder performs the inverse operation of the encoder and regenerates the audio signal.

5.5 CVSD Encoder Output Bit Rate (CVSD Bit Rate)

The CVSD bit rate for encoding the band-limited audio signal is a function of the desired audio quality and the PCM format characteristics. The minimum and maximum CVSD bit rates will not be specified.

NOTE  A qualitative test of CVSD with a tactical aircraft intercom system (ICS) yielded the following results:
 (1) intelligible, robotic sounding audio at 12 kilobits/second; (2) good quality audio at 16 kilobits/second; and (3) audio quality did not significantly improve as the bit rate was increased above 32 kilobits/second.

Appendix F contains performance criteria for the CVSD encoder and decoder when operated at 16 or 32 kilobits/second.

5.6 CVSD Word Structure

The digitized audio signal from the CVSD encoder's serial output shall be inserted into the PCM stream as shown in figure 5-1. The most significant bit (MSB) shall be the most stale sample (first in). The least significant bit (LSB) shall be the most recent sample (last in).

Figure 5-1. Insertion of CVSD encoded audio into a PCM stream.

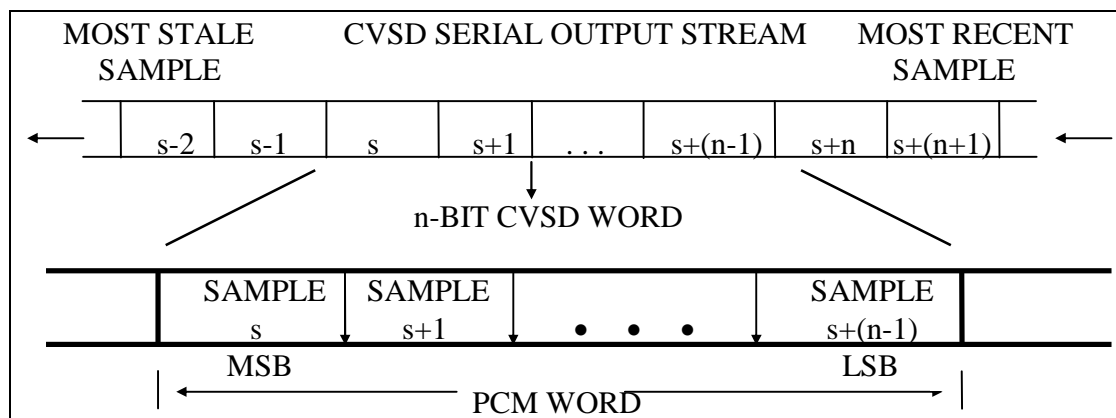

5.7 CVSD Word Sample Rate

The CVSD word sample rate is dependent on the minimum desired CVSD bit rate, the PCM word length, and the PCM word sample rate. Once the CVSD word sample rate is determined, the actual CVSD bit rate can be calculated. The decoder must be run at the same CVSD bit rate as the encoder.

NOTE  5-2

Because of the nature of CVSD encoding, over and under sampling of the CVSD output will have unpredictable results.

	<p>To simplify the reconstruction of the audio signal and minimize all encoding/decoding delays, it is STRONGLY recommended that the digitized audio words be inserted in the PCM stream at evenly spaced intervals.</p>
---	---

5.8 CVSD Bit Rate Determination

The following discussion provides a procedure for determining the CVSD bit rate based on the desired minimum CVSD bit rate and information given in the host PCM format. Note that this procedure assumes the CVSD words are inserted in a class I PCM format with constant word widths and are not subcommutated. The CVSD bit rate can be obtained by multiplying the minor frame rate by the number of times the CVSD words appear in the minor frame by the word width used for the CVSD words in the minor frame. This relationship is expressed in equation (5-1).

$$\text{CVSD BIT RATE} = \text{MINOR FRAME RATE} \bullet \text{\#CVSD WORDS PER MINOR FRAME} \bullet \text{WORD WIDTH} \quad (5-1)$$

Knowing the details on the host PCM format, equation (5-1) contains two unknowns: CVSD BIT RATE and #CVSD WORDS PER MINOR FRAME. One of these unknowns must be chosen by the user, then the other one can be calculated. The recommended procedure is to choose the desired (target value) CVSD bit rate and solve equation (5-1) for #CVSD WORDS PER MINOR FRAME. This relationship is expressed in equation (5-2).

$$\text{\#CVSD WORDS PER MINOR FRAME}_{\text{calculated}} = \frac{\text{DESIRED CVSD BIT RATE}}{\text{MINOR FRAME RATE} \bullet \text{WORD WIDTH}} \quad (5-2)$$

Next, round up (if required) the result of equation (5-2) to the nearest integer. To satisfy the evenly spaced recommendation, round up (if required) to the nearest integer that divides evenly into the number of PCM words per minor frame.

Finally, for either case, substitute the result of equation (5-2) back into equation (5-1) to determine the actual CVSD bit rate. To illustrate this procedure, consider the following numerical example for determining the CVSD bit rate. An existing PCM format has the following characteristics:

Bit rate	=	192 000 bits/second
Word width	=	12 bits/word
Minor frame rate	=	100 frames/second
Words per minor frame	=	160 words/minor frame

To insert a serial CVSD bit stream with a desired (target value), CVSD bit rate of 16 000 bits/second will require the following procedure. Based on the information given, use equation (5-2) to calculate the #CVSD WORDS PER MINOR FRAME.

$$\begin{aligned} \#CVSD \text{ WORDS PER MINOR FRAME}_{CALCULATED} &= \frac{\text{DESIRED CVSD BIT RATE}}{\text{MINOR FRAME RATE} \bullet \text{WORD WIDTH}} \\ \#CVSD \text{ WORDS PER MINOR FRAME}_{CALCULATED} &= \frac{16\,000 \text{ (bits/sec)}}{100 \text{ (frames/sec)} \bullet 12 \text{ (bits/word)}} \\ \#CVSD \text{ WORDS PER MINOR FRAME}_{CALCULATED} &= 13.3 \text{ (words/frame)} \end{aligned}$$

Rounding up the #CVSD WORDS PER MINOR FRAME to the nearest integer yields 14. In this example, there are 160 PCM words in the minor frame. If the user needs to satisfy the evenly spaced criteria, then by inspection, the #CVSD WORDS PER MINOR FRAME will be rounded up to 16. For comparison, both cases will be substituted into equation (5-1) to yield the actual CVSD bit rate.

CASE 1: (unevenly spaced CVSD samples, NOT RECOMMENDED)

$$\#CVSD \text{ WORDS PER MINOR FRAME}_{CALCULATED} = 14 \text{ (words/frame)}$$

$$CVSD \text{ BIT RATE} = \text{MINOR FRAME RATE} \bullet \#CVSD \text{ WORDS PER MINOR FRAME} \bullet \text{WORD WIDTH}$$

$$CVSD \text{ BIT RATE}_{ACTUAL} = 100 \text{ (frames/sec)} \bullet 14 \text{ (words/frame)} \bullet 12 \text{ (bits/word)}$$

$$CVSD \text{ BIT RATE}_{ACTUAL} = 16\,800 \text{ (bits/sec)}$$

CASE 2: (evenly spaced samples, RECOMMENDED)

$$\#CVSD \text{ WORDS PER MINOR FRAME}_{CALCULATED} = 16 \text{ (words/frame)}$$

$$CVSD \text{ BIT RATE} = \text{MINOR FRAME RATE} \bullet \#CVSD \text{ WORDS PER MINOR FRAME} \bullet \text{WORD WIDTH}$$

$$CVSD \text{ BIT RATE}_{ACTUAL} = 100 \text{ (frames/sec)} \bullet 16 \text{ (words/frame)} \bullet 12 \text{ (bits/word)}$$

$$CVSD \text{ BIT RATE}_{ACTUAL} = 19\,200 \text{ (bits/sec)}$$